

**Sepem® 01 GSM**

# Operating Instructions



  
**SEWERIN**

## **Measurable success by Sewerin equipment**

---

Congratulations. You have chosen a quality instrument manufactured by Hermann Sewerin GmbH.

Our equipment will provide you with the highest standards of performance, safety and efficiency. They correspond with the national and international guide-lines.

Please read and understand the following operating instructions before using the equipment; they will help you to use the instrument quickly and competently. If you have any queries we are available to offer advice and assistance at any time.

Yours

### **Hermann Sewerin GmbH**

Robert-Bosch-Straße 3  
33334 Gütersloh, Germany  
Tel.: +49 5241 934-0  
Fax: +49 5241 934-444  
www.sewerin.com  
info@sewerin.com

### **Sewerin Ltd**

Hertfordshire  
UK  
Phone: +44 1462-634363  
www.sewerin.co.uk  
info@sewerin.co.uk

### **EDENBROS, LLC**

PO Box 247  
Saint James, MO 65559  
Phone: +1 800-526-5246  
Fax: +1 800-807-9368  
www.edenbros.com  
sales@edenbros.com

### **SEWERIN Sarl**

17, rue Ampère - BP 211  
67727 HOERDT CEDEX, France  
Tél. : +33 3 88 68 15 15  
Fax : +33 3 88 68 11 77  
www.sewerin.fr  
sewerin@sewerin.fr

### **SEWERIN IBERIA S.L.**

c/ Cañada Real de Merinas, 17  
Centro de Negocios „Eisenhower“  
Edificio 5; Planta 2 - C  
28042 Madrid, España  
Tel.: +34 91 74807-57  
Fax: +34 91 74807-58  
www.sewerin.es  
info@sewerin.es

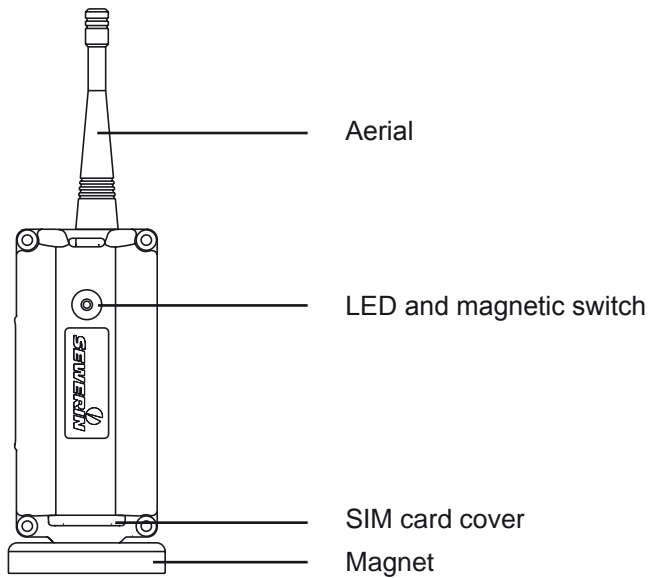

Fig. 1: **SePem 01 GSM** with aerial

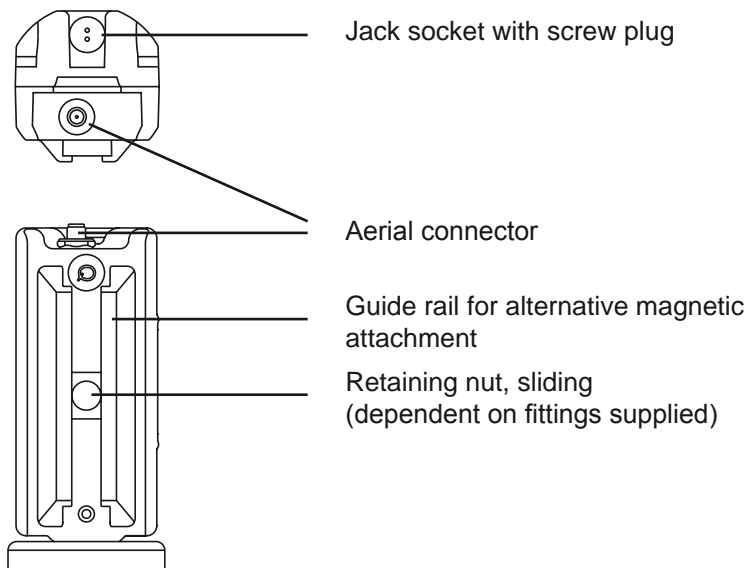

Fig. 2: **SePem 01 GSM** without antenna (viewed from above and the side)

---

## SePem 01 Interface

---

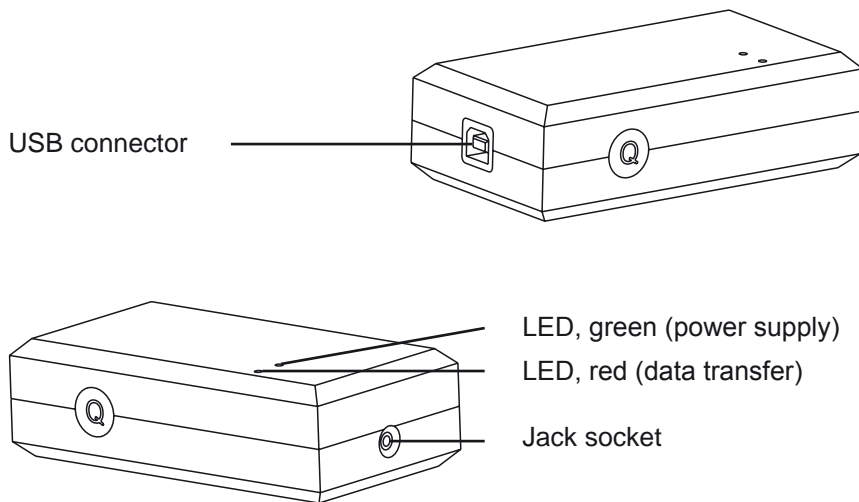

Fig. 3: **SePem 01 Interface**

---

**Operating Instructions**

# **SePem<sup>®</sup> 01 GSM**

10.11.2008 – V 1.X – 105765 – en

---

## Used symbols

---



### **CAUTION!**

This symbol is used to indicate dangers which may either result in hazards for the operators or in severe damage – or even destruction – of the product.



### **Note:**

This symbol is used to call attention to information and tips which may be helpful and which are exceeding the basic operating procedures.

---

<b>1</b>	<b>Introduction .....</b>	<b>1</b>
<b>2</b>	<b>General .....</b>	<b>2</b>
2.1	Warranty .....	2
2.2	Intended use .....	3
2.3	Safety information .....	4
<b>3</b>	<b>Monitoring water pipe networks using the SePem 01 GSM</b>	<b>5</b>
3.1	Equipment required .....	5
3.2	Monitoring process (overview) .....	6
3.3	Data transmission .....	7
<b>4</b>	<b>GSM Logger - SePem 01 GSM .....</b>	<b>8</b>
<b>5</b>	<b>SePem 01 GSM Interface programming unit .....</b>	<b>9</b>
<b>6</b>	<b>Preparing the GSM Logger for use.....</b>	<b>10</b>
6.1	Inserting the SIM card .....	10
6.2	Programming the GSM Logger .....	11
6.2.1	Equipment required.....	11
6.2.2	Preparing the device for programming.....	11
6.2.3	Changing the Logger settings .....	12
<b>7</b>	<b>Installing the GSM Logger at the measurement.....</b>	<b>13</b>
7.1	Suitable attachment points .....	13
7.2	Distance between two Loggers .....	13
7.3	Attaching the magnet and aerial to the GSM Logger .....	14
7.3.1	Magnet .....	14
7.3.2	Aerial and aerial adapter .....	15
7.4	Mounting the GSM logger and testing the network connection.	16
7.4.1	General installation instructions .....	16
7.4.2	Installation procedure.....	17
<b>8</b>	<b>Troubleshooting .....</b>	<b>19</b>
8.1	Problems with the GSM Logger .....	19
8.2	Test SMS does not function correctly .....	20

---

---

<b>9</b>	<b>Appendix .....</b>	<b>21</b>
9.1	Specifications and permitted operating conditions .....	21
9.1.1	SePem 01 GSM .....	21
9.1.2	SePem 01 GSM Interface .....	22
9.2	System requirements for computer .....	22
9.3	Terminology and abbreviations .....	23
9.4	Accessories .....	25
9.5	Firmware history .....	26
9.6	Declaration of conformity .....	27
9.7	Advice on disposal .....	28
<b>10</b>	<b>Index .....</b>	<b>29</b>



## 1 Introduction

The **SePem 01 GSM** is a logger that is able to both collect data and to automatically transmit it to the receiver. Data is transmitted using the digital mobile telephone network.

The **SePem 01 GSM** is designed for use in the early detection of leaks in water pipe networks. The system is designed for stationary operation, i.e. for use in continuous monitoring of water pipe networks at fixed measurement locations over long periods of time (several years). Generally, a large number of **GSM loggers** are installed at the same time in order to provide monitoring over a wide area.

The **SePem 01 GSM** is only suitable for the preliminary detection of leaks. Indications that a leak is present must therefore always be verified using an appropriate method (e.g. correlation).

The **SePem 01 GSM** is an enhanced version of the **SePem 01 system**, which requires an additional device to be used to read out measurement data.

## 2 General

### 2.1 Warranty

The following instructions must be complied with in order for any warranty to be applicable in respect of the functionality and safe operation of this equipment.

Hermann Sewerin GmbH cannot be held responsible for any damages resulting from non-compliance with these instructions. The warranty and liability provisions of the terms of sale and delivery of Hermann Sewerin GmbH are not affected by the information given below.

- The product must only be operated after the relevant operating instructions have been read and understood.
- The product must only be used for its intended purpose.
- The product is only suitable for use in industrial and commercial applications.
- Repairs must only be carried out by a specialist technician or by other suitably trained personnel.
- Changes or modifications to this product must not be carried out without approval from Hermann Sewerin GmbH. The manufacturer cannot be held responsible for damages if non-approved modifications have been made.
- Only accessories supplied by Hermann Sewerin GmbH may be used with this product.
- All repairs must be carried out using replacement parts that have been approved by Hermann Sewerin GmbH.
- Only approved aerials may be used.
- The manufacturer reserves the right to make technical modifications in the course of further development.

Generally applicable safety and accident-prevention regulations must be complied with, in addition to the information provided in this manual.

## 2.2 Intended use

The **SePem 01 GSM** logger is used for the acquisition of measurement data. The system is designed for use in stationary monitoring applications for water pipe networks. It must only be operated by suitably qualified employees (skilled staff, specialists and technicians) of water supply companies. The logger must only be installed in shafts and underground hydrants.

The **SePem 01 GSM Interface** is used for programming the logger. The device must only be operated using the cables supplied (USB cable, connector cable).

All applicable safety and accident prevention regulations must be complied with when operating the **SePem 01 GSM** and **SePem 01 GSM Interface**.

Specific details of the operating conditions applicable to the operation of the **SePem 01 GSM** and **SePem 01 GSM Interface** at the measurement location are provided in the appendix (Section 9.1)

The **SePem 01 GSM** and **SePem 01 GSM Interface** have been manufactured in accordance with all statutory legal and safety regulations. All components used correspond to the state-of-the-art and conform to EC requirements. The devices are safe to operate when used in accordance with the instructions provided.

### 2.3 Safety information

These operating instructions must be read carefully and in full. All advice given in these operating instructions must be followed.



**CAUTION!**

All applicable accident prevention regulations must be observed.

- Do not carry out any modifications to the **SePem 01 GSM** or otherwise change or tamper with the device in any way. Never open the device. Failure to observe the above instructions will invalidate the warranty.



**CAUTION! Hazardous to life and property.**

The **SePem 01 GSM** contains a powerful magnet. **Persons with heart pacemakers must avoid close proximity to the device.**

The **SePem 01 GSM** must be kept away from magnetic storage media (diskettes, hard drives, credit cards, etc.), monitors (PC, TV) and clocks.

- The power supply for the **SePem 01 GSM** is provided by permanently installed lithium batteries. These **batteries must only be replaced by SEWERIN Service.**
- Do not expose the **SePem 01 GSM** to temperatures above 70 °C.

The aerial on the **SePem 01 GSM** must not be damaged.

- Never carry this type of unit by the aerial.
- Never bend, kink or cut the aerial.

## 3 Monitoring water pipe networks using the SePem 01 GSM

### 3.1 Equipment required

The following items are required for data acquisition using the **SePem 01 GSM** system:

- **SePem 01 GSM**, abbreviated to: **GSM Logger** (see Section 4) for the acquisition, processing, buffering and transmission of measurement data.

There is no limit on the number of **GSM Loggers** that can be operated simultaneously.

- A **SIM card** for each **GSM Logger**.

The **SIM card** is not supplied with the device. This must allow the device to receive calls and send text messages. SIMs that only provide data and facsimile connections cannot be used.

- **SePem 01 GSM Interface**, abbreviated to: **Interface** (see Section. 5) for programming the **GSM Logger**

- **SePem software**

for programming the **GSM Logger** and evaluation of measurement data.

The **SePem software** is explained in a separate set of operating instructions.

- **Computer**

It is recommended that the connection between the **GSM Logger** and the mobile phone network be tested during installation. This requires:

- A standard **mobile phone**

#### 3.2 Monitoring process (overview)

The basic procedure for operating a **SePem 01 GSM** is as follows:

- Insert the SIM card into the **GSM Logger** (see Section 6.1)
- Program the **GSM Logger** at the computer using the **SePem software** and the **Interface** (see Section 6.2)
- Install the **GSM Logger** at the measurement location (see Section 7)
- The **GSM Logger** now operates autonomously, i.e. it acquires data at the predefined times.

Measurement results are sent automatically to the computer via SMS.

- Evaluate measurement results at the computer (see separate operating instructions for **SePem software**)

### 3.3 Data transmission

The **GSM Logger** is fitted with a module that provides data transmission across the digital GSM mobile phone network. The GSM module transmits measurement data acquired and buffered by the **GSM Logger** at predefined intervals (e.g. once per day) by means of an SMS. This is converted to an e-mail by an SMS e-mail gateway.

- Requirements:**
- E-mail connection
- Advantages:**
- Computer does not have to be switched on permanently.

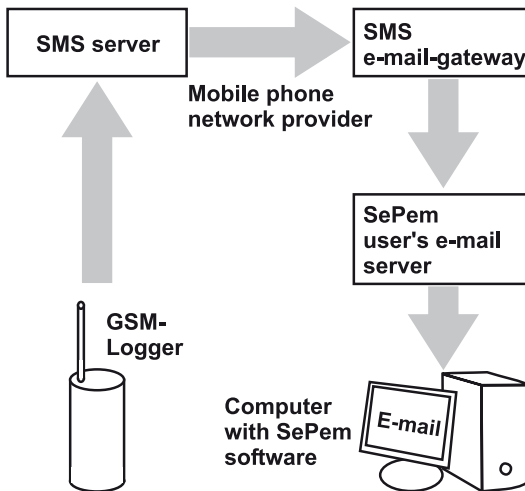

Fig. 4: Data transmission - receiving an e-mail

## 4 GSM Logger - SePem 01 GSM

The **SePem 01 GSM** (abbr: **GSM Logger** is a noise logger. It is able to acquire data from a water pipe network and to store this data. Data exchange with the computer is via a mobile phone network.

The robust, waterproof, die-cast aluminium housing means the **Logger** is suitable for permanent installation in shafts and underground hydrants.

The unit can be **mounted** on metal objects using the magnet. If it is necessary to monitor a plastic pipe, then the **GSM Logger** must be attached to the fittings.

An illustration of the **GSM Logger** with all parts labelled is provided on the inside front cover.

The **power supply** is provided by permanently installed lithium batteries that have a guaranteed lifetime of several years under normal operating conditions. ("Normal operating conditions" correspond to the **Default** settings in the **SePem software**.)



### **CAUTION!**

The **GSM Logger** must never be opened by the operator. The unit will be prone to **leakage if opened**.

Used batteries must only be replaced through the authorised SEWERIN Service scheme. There is a **risk of explosion and/or poisoning if batteries are changed incorrectly**.

A slotted nut driver must be used to remove the jack socket screw plug (supplied with **SePem 01 GSM Interface**).



## 5 SePem 01 GSM Interface programming unit

The **SePem 01 GSM Interface** (abbr.: **Interface**) is a programming tool for the **GSM Logger**. The device allows data to be transferred between the computer and the **GSM Logger**.

An illustration of the **Interface** with all parts labelled is provided on the inside front cover.

The **Interface** is always connected between the **GSM Logger** and the computer (see also Fig. 6).

Connection to the Interface	Cable	Connect to
USB	USB cable	Computer
Jack socket	Cable with jack plug	<b>GSM Logger</b>



**Note:**

When the **Interface** is connected for the first time, the computer will usually recognise it as new hardware. A message will be displayed prompting that the corresponding device driver is required. The driver can either be downloaded automatically from the Internet or installed manually from the **SePem software CD**.

Power is supplied to the device via the computer. The green LED will light up as soon as power is available.

The red LED will flash when data is being transferred between the computer and the logger.

## 6 Preparing the GSM Logger for use

### 6.1 Inserting the SIM card

Every **GSM Logger** must be fitted with a SIM card before it is used for the first time (not included with the device; see Section 3.1 for requirements). The SIM card is necessary to identify the Logger in the GSM network.

A Torx head screw driver is required for inserting the SIM card (accessory).

- Unscrew the cover.
- Slide the SIM card into the slot, as shown in Fig. 5.

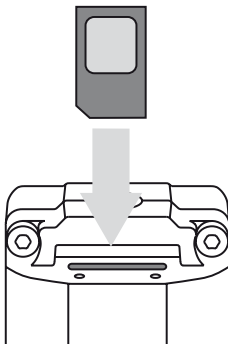

Fig. 5: Slide in the SIM card

- Use a tool (e.g. screw driver) to push the SIM card down until it locks into place.
- Screw the cover back into place, being careful to ensure that the seal is correctly positioned and does not get squashed. Tighten the screws firmly.

## 6.2 Programming the GSM Logger

Each **GSM Logger** must first be programmed before it is installed at the measurement location, i.e. data relating to measurement time, measurement duration, etc. must be transferred from the computer to the **GSM Logger**. The SIM data from the **GSM Logger** will be recorded on the computer at the same time.

### 6.2.1 Equipment required

Programming requires the following items:

- **Interface**
- Computer with **SePem software** installed
- USB cable, connector cable
- A slotted nut driver for removal of the jack socket screw plug on the **GSM Logger**

### 6.2.2 Preparing the device for programming

- Undo the jack socket screw plug on the **GSM Logger**.
- Connect the **Interface** to the computer using the USB cable.
- Connect the **GSM Logger** to the **Interface** using the connector cable.

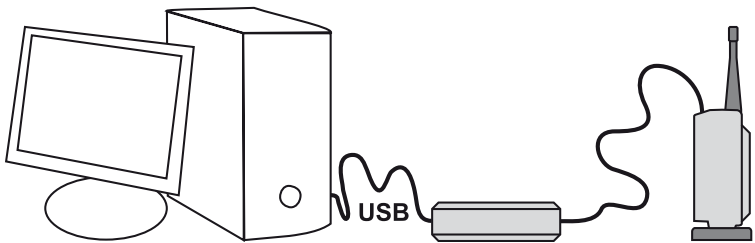

Fig 6: Programming a **GSM Logger** using an **Interface** (setup)

- Launch the **SePem Software** on the computer.

Preparation is now complete. The steps to be carried out on the computer for programming the **GSM Logger** are described in the **SePem Software** operating instructions.



**Note:**

The jack socket screw plug must always be screwed back into place once programming of the Logger is complete. Tighten the screw firmly.

### 6.2.3 Changing the Logger settings

The **GSM Logger** settings can be changed at any time using the **SePem software** and the **Interface** (see Section 6.2.2). The **GSM Logger** must be removed from the measurement location for this purpose.

## 7 Installing the GSM Logger at the measurement

### 7.1 Suitable attachment points

The **GSM Logger** can be mounted on:

- Pipes
- Fittings (slide gates, underground hydrants)

The units can be install in water pipe networks constructed from both metal and **plastic piping**. Please note the following points relating to plastic water pipe networks:

- The **GSM Logger** cannot be mounted directly on the pipe, but must instead be attached to a fitting
- Sound is not transmitted as well as in metal pipework systems.

The **GSM Logger** can be installed either vertically or horizontally. The aerial must however always be positioned vertically, pointing either upwards or downwards (see also Sections 7.3 and 7.4.1).

### 7.2 Distance between two Loggers

The distance between two Loggers and the choice of attachment point is always **dependent on local conditions** (special features of the network, pressure fluctuations, etc.).

Water pipe material	Recommended distance between Loggers [m]
Metal	300 – 500
Plastic	50 –300

For highly intermeshed water pipe networks, the distance between Loggers must be decreased appropriately.

### 7.3 Attaching the magnet and aerial to the GSM Logger

There are several possible configurations for attaching magnets and aerials to the housing. Local conditions at the measurement location must always be taken into consideration when selecting a particular type of attachment.



**Note:**

The method used to attach the magnet and aerial, and their exact positioning, have an influence on the sensitivity with which measurement data can be recorded and the quality of the network connection.

#### 7.3.1 Magnet

The magnet can be screwed to the housing at the following points (dependent on fittings supplied):

- Thread on the side opposite the aerial connector.
- Retaining nut in the guide rail

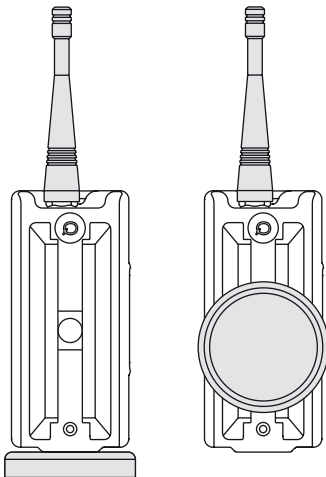

Fig. 7: Mounting points on the housing for attaching the magnet

If the magnet is attached to the retaining nut in the guide rail, then it is also possible to slide the magnet up and down until the optimum position for a given measurement location is found.

Where the **GSM Logger** is to be mounted in a horizontal position, the magnet should be screwed onto the guide rail in a position as far as possible from the aerial connector; this will maximise the sensitivity of the internal microphone.

### 7.3.2 Aerial and aerial adapter

The aerial can be screwed directly into the threaded aerial connector.

If there is limited space at the measurement location, then an aerial adapter with magnetic attachment (optional accessory) can be used. This is screwed into place between the aerial connector and the aerial. This provides much more flexibility in positioning the aerial during installation. The magnetic attachment should be fitted at the measurement location in such a way that the aerial does not come into contact with any other objects (e.g. walls of the shaft).



Fig. 8: Aerial adapter

- Check carefully to ensure that all **contacts are clean and dry** before screwing in the aerial/aerial adapter.
- The aerial/aerial adapter must be tightened firmly **by hand until the end stop is reached**. This is necessary in order to ensure that the unit is properly leak-tight and to guarantee a good radio signal.



#### **CAUTION! Risk of damage!**

Never use **any tools** to assist in tightening the aerial/aerial adapter. This could lead to damage to the internal contacts.

### 7.4 Mounting the GSM logger and testing the network connection

The **GSM Logger** is mounted at the measurement location using the magnet.

If an aerial adapter is used then the aerial must also be mounted using the magnetic attachment. It is important in all cases that installation is carried out very carefully, especially when positioning the aerial.

#### 7.4.1 General installation instructions

- Ensure that a good metal-to-metal contact is formed between the Logger magnet and the body to which it is attached.

It is important that structure-borne sound is not damped by dirt, mud or rust. Clean the attachment point if necessary before mounting the **GSM Logger**.

- Although the **GSM Logger** must have a good contact at the magnet attachment point, the **aerial must not touch any surrounding metal parts at any point**.

If an aerial adapter is used, then mount the aerial using the magnetic attachment in a position that ensures the aerial is kept well away from all metal parts at the measurement location.

- The aerial must not be bent or shortened. The available space should be evaluated to ensure that the aerial will remain straight and will not come into contact with any metal objects after the shaft cover is closed.



### 7.4.2 Installation procedure

- Ensure that all preparatory work has been carried out: SIM card inserted; device programmed; magnet and aerial attached.
- Mount the **GSM Logger** in various test positions at the measurement location. Continue until the best possible installation position is found. If necessary, change the positions at which the magnet and aerial are attached.
- Remove the **GSM Logger** again.
- Move a magnet (e.g. the magnet from another **Logger**) over the magnetic switch on the **GSM Logger**. The LED will start to flash twice a second.

The next two steps of the procedure must be completed within **75 s**.

- Mount the **GSM Logger** at the measurement location.
- Replace the manhole cover.
- Wait until **at least 2 minutes** have passed since the GSM Logger was activated (**maximum 10 minutes**).
- Use a mobile phone to make a call to the **GSM Logger**. Dial the number of the SIM card that was installed in the **GSM Logger**. The **GSM Logger** will answer with a whistling sound. A test SMS message will be received by the mobile phone if the network connection is functioning correctly.

The time taken for the test SMS to arrive may vary considerably, depending on the volume of traffic on the mobile phone network. The test SMS contains information indicating the quality of the network connection.

Number	Reception quality	Comment
0	Inadequate	Check the way the Logger is mounted and optimise position (see Section 8.2)
1	Adequate	
≥ 2	Good	

The **GSM Logger** has been successfully installed when:

- The test SMS has been transmitted successfully
- The reception quality was at least 'Adequate'



**Note:**

The successful transmission of a test SMS only confirms that the network connection was functioning at the time of the test. It does not guarantee reliable operation on an ongoing basis. Therefore, always ensure that the reception quality is at least '1'.

## 8 Troubleshooting

**Possible sources of problems with the SePem 01 GSM are:**

- Fault with the **GSM Logger**
- Quality of the network connection

The quality of the network connection may vary considerably. For example, this can be affected by the weather and parked cars. In practice, this means that a network connection may suddenly be lost, even if it has previously been verified using a test SMS.

SEWERIN Service will be pleased to provide assistance in cases where the tips in the following chapters do not help in identifying the cause of a fault (Tel.: +49 5241 934-250).

### 8.1 Problems with the GSM Logger

Problem/symptom	Cause > Solution
Logger cannot be activated (LED does not flash)	<ul style="list-style-type: none"> <li>● Flat battery &gt; send Logger to SEWERIN Service</li> <li>● Magnet too weak &gt; Use a genuine magnet of the type used with the Logger</li> </ul>
LED flashing <ul style="list-style-type: none"> <li>● Initially normal</li> <li>● Rapid flashing after 90 s</li> </ul> The logger switches off after another 3 s.	<ul style="list-style-type: none"> <li>● SIM card not installed in Logger &gt; Insert SIM card (see Section 6.1)</li> <li>● SIM card inserted incorrectly &gt; Reinsert SIM card (see Section 6.1)</li> </ul>

8.2 Test SMS does not function correctly

Problem/symptom	Cause > Solution
<p>No ringing tone heard on mobile phone, call forwarded to voicemail for example. (Cannot dial in to Logger)</p>	<ul style="list-style-type: none"> <li>● Waiting time (2 min) not elapsed &gt; Continue to wait</li> <li>● Waiting time (10 min) exceeded &gt; Repeat installation procedure &gt; Retransmit test SMS</li> <li>● No network connection &gt; Optimise installation position (see below)</li> <li>● Measurement location unsuitable e.g. reception blackspot &gt; Choose another location</li> </ul>
<p>Engaged signal heard instead of ringing tone on mobile phone</p>	<ul style="list-style-type: none"> <li>● Waiting time (2 min) not elapsed &gt; Hang up &gt; Wait 15 s &gt; Dial again</li> </ul>
<p>Ringing tone not heard on mobile phone, Logger does not transmit whistling sound</p>	<ul style="list-style-type: none"> <li>● Logger installation is not ideal &gt; Optimise installation position (see below)</li> <li>● SIM card unsuitable (See Section 3.1 for requirements) &gt; Choose another SIM card</li> </ul>
<p>Logger transmits whistling sound, no SMS received on mobile phone</p>	<ul style="list-style-type: none"> <li>● Caller ID not activated on mobile phone &gt; Activate Caller ID</li> <li>● Signal too weak &gt; Optimise installation position (see below)</li> </ul>

**Check the way the GSM Logger is mounted and optimise position**

- Is the aerial connector on the logger clean and dry? Moisture will reduce the quality of the network connection.
- Is the logger fitted with a SEWERIN-approved aerial?
- Can the Logger be repositioned at the measurement location? Please refer to the instructions in Section 7.3.
- Is it possible to replace the metal manhole cover with a plastic manhole cover?

## 9 Appendix

### 9.1 Specifications and permitted operating conditions

#### 9.1.1 SePem 01 GSM

Construction:	Die-cast aluminium housing
Protection rating:	IP68
Power supply:	Lithium batteries (must only be replaced through authorised SEWERIN Service scheme)
Operating time:	Up to 10 years (depending on settings and network quality)
Weight:	Approx. 675 g (with aerial and magnet)
Dimensions (W × D × H):	108 × 51 × 50 mm (without aerial and magnet)
Length of aerial:	80 mm
Operating temperature:	-20 °C – +55 °C
Storage temperature:	-20 °C – +70 °C
Data memory:	64 kB
Sampling rate:	1 s – 1 h
Communication:	GSM and cable
Frequency:	Quad band GSM (850/900/1800/1900 MHz)
Permitted operating environments:	<ul style="list-style-type: none"> <li>● For installation in shafts and underground hydrants</li> <li>● Submersible to 1 m</li> </ul>
Non-permitted operating environments:	<ul style="list-style-type: none"> <li>● In liquids other than water</li> <li>● In aggressive media</li> <li>● In potentially explosive areas</li> </ul>
Permissible relative humidity:	100%

**9.1.2 SePem 01 GSM Interface**

Construction:	Plastic
Protection rating:	IP20
Power supply:	Externally via USB, i.e. powered from the computer
Weight:	Approx. 70 g
Dimensions (W × D × H):	100 × 54 × 30 mm
Operating temperature:	0 °C – +50 °C
Storage temperature:	-20 °C – +70 °C
Communication:	USB
Permitted operating environments:	<ul style="list-style-type: none"><li>● Indoors</li><li>● In vehicles</li></ul>
Non-permitted operating environments:	<ul style="list-style-type: none"><li>● Outdoors</li><li>● In liquids</li><li>● In aggressive media</li><li>● In potentially explosive areas</li></ul>
Permissible relative humidity:	80%

**9.2 System requirements for computer**

Operating system:	Microsoft Windows 2000 SP4, XP 32/64 SP2, Vista 32/64
RAM:	Depends on operating system <ul style="list-style-type: none"><li>● 2000: 256 MB</li><li>● XP: 512 MB (1024 MB recommended)</li><li>● Vista: 1024 MB (2048 MB recommended)</li></ul>
Features:	<ul style="list-style-type: none"><li>● USB 2.0 interface</li><li>● RS-232 serial interface</li></ul>
Screen resolution:	1024 × 768 pixels (1280 × 1024 pixels recommended)

### 9.3 Terminology and abbreviations

<b>Attachment point</b>	<ul style="list-style-type: none"> <li>● Point at which the Logger is attached to the pipe or fitting i.e. where it makes physical contact with the water pipe network</li> </ul>
<b>Background noise</b>	<ul style="list-style-type: none"> <li>● Unwanted electromagnetic radiation from various sources (e.g. street lamps)</li> </ul>
<b>Device driver</b>	<ul style="list-style-type: none"> <li>● Software that allows a computer to operate cooperatively with a connected (or installed) device.</li> </ul>
<b>Firmware</b>	<ul style="list-style-type: none"> <li>● Term used to refer to software in electronic devices (e.g. Logger)</li> <li>● to distinguish it from PC software</li> </ul>
<b>GSM</b>	<ul style="list-style-type: none"> <li>● Global System for Mobile communications</li> <li>● Name given to a type of digital mobile phone network</li> </ul>
<b>Install</b>	<ul style="list-style-type: none"> <li>● Mount a Logger at the measurement location</li> </ul>
<b>Measurement data</b>	<ul style="list-style-type: none"> <li>● Data that is collected and stored by a Logger during a measurement</li> </ul>
<b>Measurement location</b>	<ul style="list-style-type: none"> <li>● Location in the water pipe network where a Logger is installed for the acquisition of measurement data</li> </ul>
<b>Read out</b>	<ul style="list-style-type: none"> <li>● Transfer data from Logger to computer</li> </ul>
<b>SIM</b>	<ul style="list-style-type: none"> <li>● Subscriber Identity Module</li> <li>● Smart card for mobile telephones that identifies the user to the network</li> </ul>
<b>SMS e-mail gateway</b>	<ul style="list-style-type: none"> <li>● Transfers information between different types of communication networks</li> <li>● Allows SMS messages to be sent and received using devices that are not mobile phones</li> <li>● In this case: Converts an SMS to an e-mail</li> </ul>

<b>Test SMS</b>	<ul style="list-style-type: none"><li>● For checking the quality of the network connection</li><li>● A mobile phone must used to conduct this test</li></ul>
-----------------	--



---

## 9.4 Accessories



### Safety line, 1.2 m

Order no.: SF01-Z0300

- For lowering into shafts, incl. spring clamp



### Aerial adapter with magnetic attachment

Order no.: SF01-Z0700

- For attaching the aerial to the SePem 01 GSM
- For vertical mounting of the SePem 01 GSM
- Cable length, 0.4 m
- Also available with cable lengths 1.0 m, 2.5 m, 5.0 m

### Torx head screwdriver

Order no.: 7221-0019

- For removal/fastening of the SIM card cover on the SePem 01 GSM

9.5 Firmware history

SePem 01 GSM

Version	Change
1.000	Release version

## 9.6 Declaration of conformity



### EC Declaration of Conformity

Product: **SePem 01 GSM**  
Intended use: System for detection of water leaks:  
Battery-powered GSM data logger  
Manufacturer: Hermann Sewerin GmbH  
Address: Robert-Bosch-Str.3  
33334 Gütersloh - Germany

The product complies with the following directives:

**FTEG** Law applicable to radio and telecommunications terminal equipment  
**1999/5/EG (R&TTE)** Radio and telecommunications terminal equipment

For evaluation of conformity the following harmonised standards apply:

EN 50401:2006  
EN 60950-1:2001  
ETSI EN 301489-1 V1.6.1  
ETSI EN 301489-7 V1.2.1  
ETSI TS 151010-1 V5.10.0

Gütersloh, 17.03.2008

A handwritten signature in black ink that reads "S. Sewerin".

Dr. S. Sewerin  
(General Manager)

**9.7 Advice on disposal**

The European Waste Catalogue (EWC) governs the disposal of appliances and accessories.

Description of waste	Allocated EWC waste code
Device	16 02 13
Disposable battery, rechargeable battery	16 06 05

**Used equipment**

Used equipment can be returned to Hermann Sewerin GmbH. We will arrange for the appliance to be disposed of appropriately by certified specialist contractors free of charge.

---

## 10 Index

### A

Aerial 14, 15  
Aerial adapter 15

### D

Data transmission 7  
Distance 13

### E

Error 19

### G

GSM Logger 8  
Attachment points 13  
Distance between units 13  
Mounting 17  
Optimising installation 20  
Power supply 8  
Problems with 19

### I

Installation instructions, general 16

### L

Logger programming *see* Programming

### M

Magnet 14  
Monitoring  
Process 6

### P

Plastic piping 13  
Programming 9, 11  
Changing settings 12  
Preparation 11  
Programming interface 9

### R

Radio connection *see also* Data transmission

### S

SIM card  
Inserting 10  
Requirements 5

### T

Test SMS  
Problems with 20  
Reception quality 17  
Transmit 17

### U

Use 1, 3

**Hermann Sewerin GmbH**  
Robert-Bosch-Straße 3 · 33334 Gütersloh · Germany  
Telefon +49 5241 934-0 · Telefax +49 5241 934-444  
[www.sewerin.com](http://www.sewerin.com) · [info@sewerin.com](mailto:info@sewerin.com)