

## **UT 830**



# UT 830 R

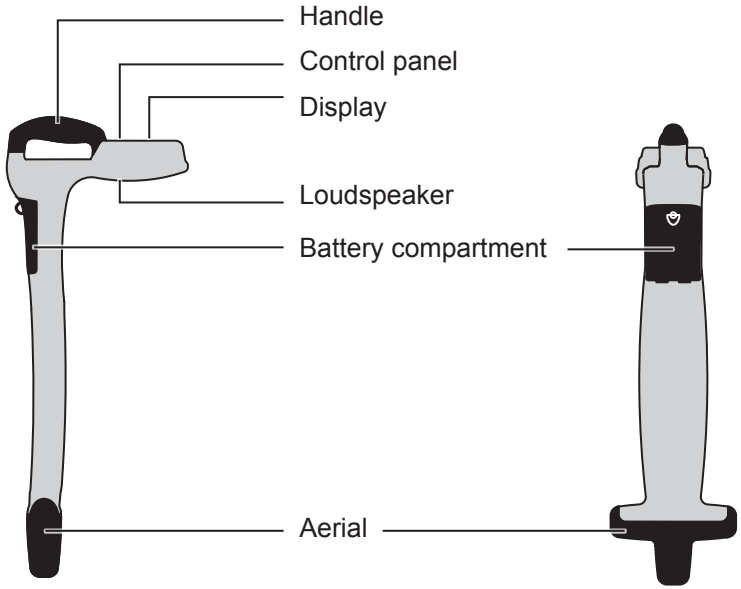

Fig. 1: UT 830 R receiver

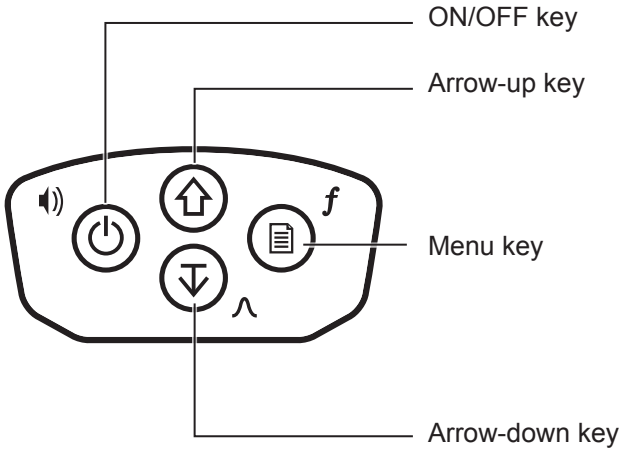

Fig. 2: UT 830 R control panel

## UT 830 T

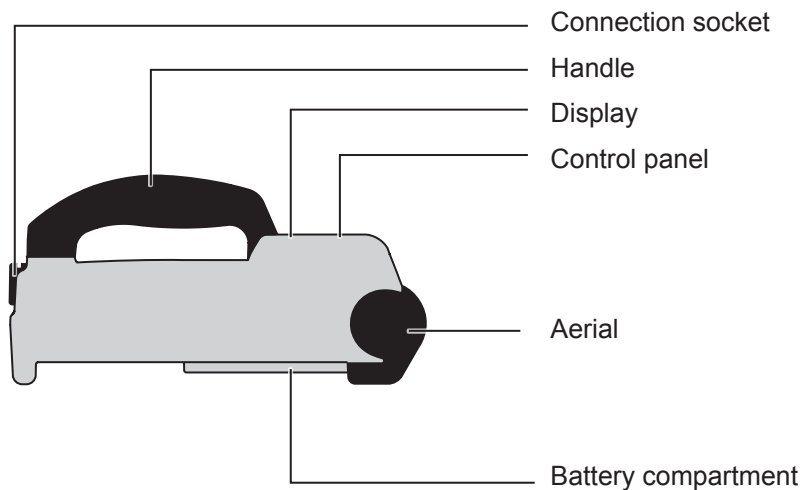

Fig. 3: **UT 830 T** generator

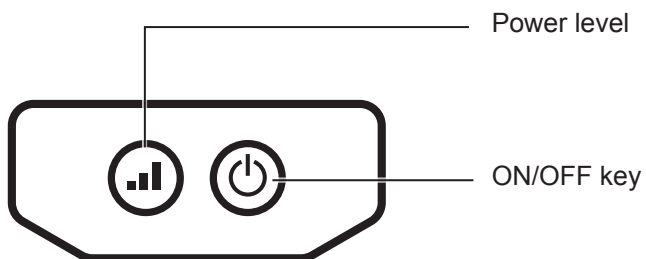

Fig. 4: **UT 830 T** generator control panel

# Information about this document

The warnings and notes in the document mean the following:



**WARNING!**

Risk of personal injury. Can result in serious injury or death.

---



**CAUTION!**

Risk of personal injury. Can result in injury or a risk to health

---

---

**NOTICE!**

Risk of damage to property.

---

---

**Note:**

Tips and important information.

---

Enumerated lists (numbers, letters) are used for:

- Instructions that must be followed in a specific sequence

Bulleted lists (bullet points, dashes) are used for:

- Lists
- Instructions comprising only one action

---

<b>1</b>	<b>Introduction .....</b>	<b>1</b>
1.1	Warranty .....	1
1.2	Purpose .....	1
1.3	Intended use .....	2
1.4	General safety information .....	3
<b>2</b>	<b>UT 830 R receiver .....</b>	<b>4</b>
2.1	General .....	4
2.2	Controls .....	5
2.3	Display .....	6
2.4	Settings (menu) .....	8
2.4.1	Units .....	9
2.4.2	Contrast .....	9
2.4.3	Information .....	10
2.4.4	Passive frequencies .....	10
2.5	Locating modes .....	11
2.6	Replacing disposable/rechargeable batteries .....	11
<b>3</b>	<b>UT 830 T generator .....</b>	<b>13</b>
3.1	General .....	13
3.2	Controls .....	13
3.3	Display .....	14
3.4	Operating modes .....	15
3.5	Replacing disposable/rechargeable batteries .....	15
<b>4</b>	<b>Line location .....</b>	<b>17</b>
4.1	General information on line location .....	17
4.2	Active location .....	17
4.2.1	Energizing a line .....	17
4.2.1.1	Galvanic energizing .....	18
4.2.1.2	Inductive energizing .....	19
4.2.1.3	Energizing with a cable clamp .....	20
4.2.2	Locating a line .....	22
4.2.3	Problems in locating adjacent lines .....	23
4.2.3.1	Errors arising from the use of acoustic location alone .....	23
4.2.3.2	Tip 1: Check the directional arrows .....	24
4.2.3.3	Tip 2: Use the PEAK function .....	24
4.3	Passive location .....	25
4.4	Locating errors .....	26

---

---

<b>5</b>	<b>Troubleshooting .....</b>	<b>27</b>
5.1	Problems with the receiver .....	27
5.2	Problems with the generator .....	28
<b>6</b>	<b>Appendix .....</b>	<b>29</b>
6.1	Technical data .....	29
6.1.1	UT 830 R receiver .....	29
6.1.2	UT 830 T generator .....	30
6.2	Accessories and consumables .....	31
6.3	EC Declaration of Conformity .....	31
6.4	Advice on disposal .....	31
<b>7</b>	<b>Index .....</b>	<b>32</b>

# 1 Introduction

## 1.1 Warranty

The following instructions must be complied with in order for any warranty to be applicable regarding functionality and safe operation of this equipment. The product must only be operated by qualified specialist technicians.

- Read these operating instructions prior to operating the product.
- Use the product only as intended.
- Repairs and maintenance must only be carried out by specialist technicians or other suitably trained personnel. Only spare parts approved by Hermann Sewerin GmbH may be used when performing repairs.
- Use only suitable battery types.
- Changes or modifications to this product may only be carried out with the approval of Hermann Sewerin GmbH.
- Use only Hermann Sewerin GmbH accessories for the product.

Hermann Sewerin GmbH shall not be liable for damages resulting from the non-observance of this information. The warranty conditions of the General Terms and Conditions (AGB) of Hermann Sewerin GmbH are not affected by this information.

In addition to the warnings and other information in these Operating Instructions, always observe the generally applicable safety and accident prevention regulations.

The manufacturer reserves the right to make technical changes.

## 1.2 Purpose

**UT 830** is an electronic locating system for detecting electrically conductive lines laid in the ground. The system comprises the **UT 830 R** receiver and the **UT 830 T** generator.

The **UT 830** can be used for:

- Locating and tracking lines

Lines refers here to both power and signal cables as well as supply pipes, for example.

- Determining the depth of a line

Location can be carried out passively or actively. For active location the required electromagnetic field is generated by means of a generator. Passive location makes use of existing electromagnetic fields.

As with other systems, it is always advisable to check the plausibility of the result of the **UT 830** locating process.

---

**Note:**

All descriptions in these operating instructions refer to the device as delivered (factory settings). The manufacturer reserves the right to make changes.

---

### 1.3 Intended use

**UT 830** is intended for professional industrial and commercial use. The appropriate specialist knowledge is required to operate the device.

---

**Note:**

If necessary, learn more about pipeline location theory before commencing practical work with **UT 830**.

---

The system must only be used for the applications specified in Section 1.2.



## 1.4 General safety information

- Contact the local utility companies to establish the route of underground cables and pipes before commencing locating work.
- Before starting work, check that the equipment is in good working order. Never use damaged or faulty equipment.
- Never use the equipment in the vicinity of explosive areas.
- Always adequately secure the setup locations of the equipment to prevent injury to persons and damage to vehicles.
- Always observe the applicable safety regulations when working on electrical installations (e.g. power cables).
- Do not drop the devices.
- Never place the devices in places where they are at risk of falling.
- Ensure that no dirt or moisture can get into the connections on the devices.
- Always observe the permitted operating and storage temperatures.
- Do not immerse the devices in liquids.

## 2 UT 830 R receiver

### 2.1 General

The **UT 830 R** receiver receives the signals from electromagnetic fields. The signals are relayed:

- audibly via the loudspeaker
- visually on the display

The field strength is displayed in graphical and numerical form. The directional arrows help guide you towards the line being located.





You will find an overview with the names of the receiver parts inside the front cover (Fig. 6).

The **UT 830 R** receiver can be used for both active and passive location. For active location the receiver has an automatic gain control. During the locating process it adjusts to the maximum sensitivity when searching and the optimum sensitivity when determining the exact location.

The selected volume of the loudspeaker does not affect the sensitivity of the device, i.e. loud signals are not necessarily strong signals.

## 2.2 Controls

You will find an overview with the names of the receiver controls inside the front cover (Fig. 2).

Key	Action	Result
	Press the key	<ul style="list-style-type: none"> <li>● Switch device on</li> <li>● In measuring mode:               <ul style="list-style-type: none"> <li>– Change the volume</li> </ul> </li> <li>● In the menu:               <ul style="list-style-type: none"> <li>– Cancel</li> <li>– Return to measuring mode</li> </ul> </li> </ul>
	Hold down the key	<ul style="list-style-type: none"> <li>● Switch device off</li> </ul>
	Press the key	<ul style="list-style-type: none"> <li>● In measuring mode in passive location:               <ul style="list-style-type: none"> <li>– Increase the gain</li> </ul> </li> <li>● In the menu:               <ul style="list-style-type: none"> <li>– Move up</li> </ul> </li> </ul>
	Press the key	<ul style="list-style-type: none"> <li>● In measuring mode in active location:               <ul style="list-style-type: none"> <li>– Measure the depth of the located line</li> </ul> </li> <li>● In measuring mode in passive location:               <ul style="list-style-type: none"> <li>– Reduce the gain</li> </ul> </li> <li>● In the menu:               <ul style="list-style-type: none"> <li>– Move down</li> </ul> </li> </ul>
	Hold down the key	<ul style="list-style-type: none"> <li>● In measuring mode in active location:               <ul style="list-style-type: none"> <li>– Open PEAK function</li> </ul> </li> </ul>
	Press the key	<ul style="list-style-type: none"> <li>● In the menu:               <ul style="list-style-type: none"> <li>– Open menu item</li> </ul> </li> </ul>
	Press the key briefly	<ul style="list-style-type: none"> <li>● In measuring mode:               <ul style="list-style-type: none"> <li>– Change locating mode</li> </ul> </li> <li>● In measuring mode in passive location:               <ul style="list-style-type: none"> <li>– Change the frequency</li> </ul> </li> </ul>
	Hold down the key	<ul style="list-style-type: none"> <li>● Open the menu</li> </ul>

### 2.3 Display

The elements and symbols that appear on the display depend on the selected locating mode.

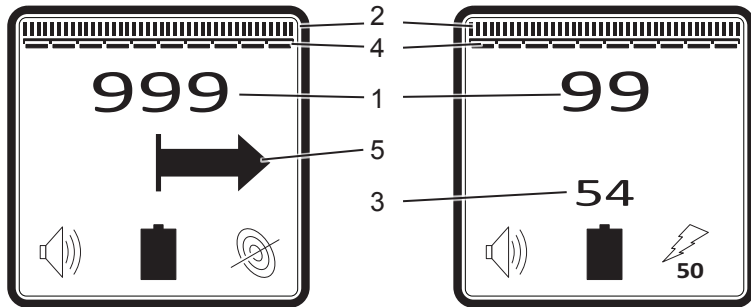

Fig. 5: Display on the UT 830 R receiver during active (left) and passive (right) locating.

1 Field strength (numerical), 2 Field strength (graphical), 3 Gain (numerical), 4 Gain (graphical), 5 Directional arrow

#### Display elements

- |                                     |   |
|-------------------------------------|---|
| <b>1 Field strength (numerical)</b> | Shows the field strength as a numerical value.<br>Value ranges: <ul style="list-style-type: none"> <li>● 0 – 999            In active location</li> <li>● 0 – 99             In passive location</li> </ul> |
| <b>2 Field strength (graphical)</b> | Shows the field strength as a graphical display. <ul style="list-style-type: none"> <li>● The more segments that are visible, the higher the field strength.</li> </ul>                                     |
| <b>3 Gain (numerical)</b>           | In passive location only. Shows the gain as a numerical value.  |
| <b>4 Gain (graphical)</b>           | Shows the gain as a graphical display. <ul style="list-style-type: none"> <li>● The more segments that are visible, the higher the gain.</li> </ul>   |
| <b>5 Directional arrow</b>          | In active location only. Indicates the direction of the line being located.   |

## Display symbols

### Volume



Shows the volume setting.

- A low volume extends the lifespan of the batteries.

### Battery



Shows the battery charge.

- Symbol filled in:  
Batteries are fully charged
- Symbol not filled in and outline flashing:  
Batteries need replacing  
(see Section 2.6 on page 11).

### Locating mode



Shows the selected locating mode (see Section 2.5 on page 11).

## 2.4 Settings (menu)

The menu can be used for making settings and for retrieving information about the device. The following menu items are available:

- **Units**
- **Contrast**
- **Info**
- **PowerSetup** (passive frequencies)

### Opening the menu

The device is switched on.

- Hold down the Menu key.  
The menu appears.

### Opening a menu item

The menu is open.

1. Press the arrow-up or arrow-down key to highlight a menu item.
2. Press the Menu key.  
The selected menu item is opened.

### Exiting the menu or a menu item

The menu or a menu item is open.

- Press the ON/OFF key.  
The device switches from the menu item back to the menu.





OR

The device switches from the menu back to measuring mode.

### 2.4.1 Units







The **Units** menu item is used for defining the unit for measuring the depth.

Action	Press the key
<ul style="list-style-type: none"> <li>Select unit</li> </ul>	 or 
<ul style="list-style-type: none"> <li>Accept selection and return to measuring mode</li> </ul>	
<ul style="list-style-type: none"> <li>Cancel (return to menu without accepting change)</li> </ul>	

### 2.4.2 Contrast



The **Contrast** menu item is used for setting the display contrast.

Action	Press the key
<ul style="list-style-type: none"> <li>Select contrast strength</li> </ul>	 or 
<ul style="list-style-type: none"> <li>Accept selection and return to measuring mode</li> </ul>	
<ul style="list-style-type: none"> <li>Cancel (return to menu without accepting change)</li> </ul>	

### 2.4.3 Information



The **Info** menu item shows information about the device.

Action	Press the key
<ul style="list-style-type: none"> <li>Exit the menu item and return to the menu</li> </ul>	

#### Available information

- Firmware version
- Serial number
- Date of calibration and configuration
- Total operating time
- Power line frequency
- Battery voltage

### 2.4.4 Passive frequencies



The **PowerSetup** menu item is used for activating all the frequencies required for passive location.

Action	Press the key
<ul style="list-style-type: none"> <li>Select frequency</li> </ul>	or
<ul style="list-style-type: none"> <li>Activate or deactivate frequency</li> </ul>	
<ul style="list-style-type: none"> <li>Accept selection and return to measuring mode</li> </ul>	



## 2.5 Locating modes

The device can be used for active and passive locating. The selected locating mode is indicated by means of symbols.

### Active location



Used for locating lines that are energized by a generator with a frequency of 83.0775 kHz.

### Passive location



Used for locating power cables.

Available frequencies: 50 Hz, 100 Hz, 150 Hz

Alternatively, the receiver is also available with the frequencies 60 Hz, 120 Hz and 180 Hz.

## 2.6 Replacing disposable/rechargeable batteries

The device can be operated with either disposable or rechargeable batteries.

---

### NOTICE! Risk of damage due to leaking batteries

- Never mix power sources of different types (disposable or rechargeable), capacity, condition (new or used) or manufacturer.
- 

The battery compartment cover is locked with a quick-release fastener.

1. Turn the quick-release fastener to open the battery compartment.
2. Remove the used batteries.
3. Insert new batteries. Ensure correct polarity (Fig. 6).

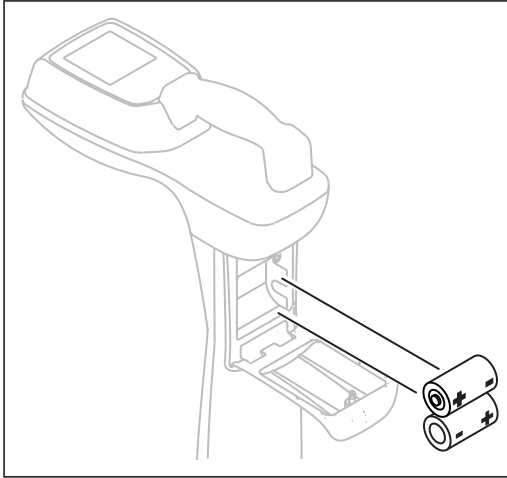

Fig. 6: Changing the batteries in the **UT 830 R** receiver – battery polarity

4. Close the battery compartment.
5. Check that the device is ready for operation by switching it on.
  - If the battery polarity is incorrect, the device will not switch on.

## 3 UT 830 T generator

### 3.1 General



The **UT 830 T** generator can be used to energize lines both galvanically and inductively. The generator is, therefore, often also referred to as a transmitter.

The **UT 830 T** generator energizes the line to be located with a frequency of 83.0775 kHz, which is detected by the **UT 830 R** receiver.

You will find an overview with the names of the generator parts inside the front cover (Fig. 3).

### 3.2 Controls

You will find an overview with the names of the generator controls inside the front cover (Fig. 8).

Key	Action	Result
	Press the key	• Switch device on
	Hold down the key	• Switch device off
	Press the key	• Change the power level

### 3.3 Display



Fig. 7: UT 830 T generator display

#### Display symbols

##### Operating mode



Shows the selected operating mode or the error that occurs on energizing (see Section 3.4 on page 15).

##### Power level



Shows the selected power level.

##### Battery



Shows the battery charge.

- Symbol filled in:  
Batteries are fully charged
- Symbol not filled in and outline flashing:  
Remaining capacity is low, batteries need replacing (see Section 3.5 on page 15).

### 3.4 Operating modes

The device can be used to energize lines galvanically, inductively and with a cable clamp. The selected operating mode is indicated by means of symbols.

#### Inductive energizing



Symbol for inductive energizing



Symbol for error during inductive energizing

- Possible causes of error:
  - Remaining battery capacity too low
  - Faulty aerial

#### Galvanic energizing and cable clamp



Symbol for galvanic energizing or energizing with cable clamp



Symbol for error during galvanic energizing or energizing with cable clamp

- Possible causes of error:
  - Electrical circuit interrupted
  - Not enough or no current flowing through the line to be located

### 3.5 Replacing disposable/rechargeable batteries

The device can be operated with either disposable or rechargeable batteries.

---

#### NOTICE! Risk of damage due to leaking batteries

- Never mix power sources of different types (disposable or rechargeable), capacity, condition (new or used) or manufacturer.
- 

The battery compartment cover is locked with a quick-release fastener.

1. Turn the quick-release fastener to open the battery compartment.
2. Remove the used batteries.
3. Insert new batteries. Ensure correct polarity (Fig. 8).

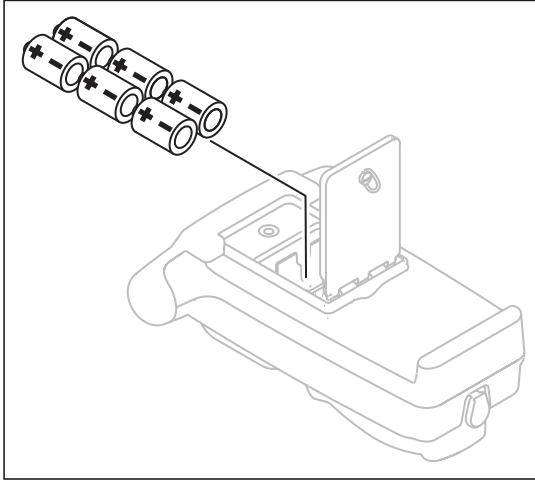

Fig. 8: Changing the batteries in the **UT 830 T** generator – battery polarity

4. Close the battery compartment.
5. Check that the device is ready for operation by switching it on.
  - If the polarity of one battery is incorrect, an error message may appear when the device is switched on. The device will then switch off again automatically.
  - If the polarity of all the batteries is incorrect, the device will not switch on.

## **4 Line location**

### **4.1 General information on line location**

In order for a line to be located, it must carry a current with a certain frequency so that an electromagnetic field is generated. It is not the line itself that is detected but rather the associated electromagnetic field.

There are two locating modes:

- active location
- passive location

### **4.2 Active location**

In active location a generator is used to produce an electromagnetic field around the line to be located. The energized line can then be located.

#### **4.2.1 Energizing a line**

In active location the line is galvanically or inductively energized. Lines can also be energized using a cable clamp.

### 4.2.1.1 Galvanic energizing

Galvanic energizing involves supplying power from a generator to the line via a cable. This is only possible if an electrical connection can be made at an exposed part of the line.

Energizing requires a generator and a set of cables.

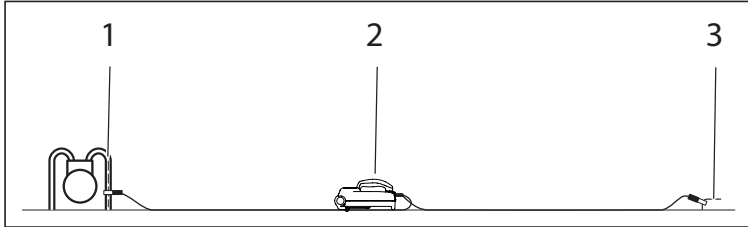

Fig. 9: Arrangement of devices for galvanic energizing  
1 Electrical connection at the line to be located, 2 Generator,  
3 Earthing spike



#### **WARNING! Risk of injury from high voltage**

High voltages can occur at exposed parts of lines.

- Carry out the instructions in the specified order.
- Always switch off the generator before moving the earthing spike.

---

The generator is switched off.

1. Firmly stick an earthing spike into the ground.

If possible, position the earthing spike at an angle of 90° to the line.

2. Connect the phone jack from the set of cables to the generator.
3. Connect the black cable from the set of cables to the earthing spike.
4. Connect the red cable from the set of cables to the line to be energized.



**CAUTION! Risk of accident in the work area**

Equipment and cables lying on the ground can cause a tripping hazard.

- Secure the entire work area to prevent access by third parties.
- 

5. Switch on the generator.

6. Select a suitable power level.

The line is energized with the selected power.

#### 4.2.1.2 Inductive energizing

Inductive energizing involves positioning the generator above the line to be located. The electromagnetic field generated by the generator causes a current flow in the line to be located.

Energizing only requires a generator.

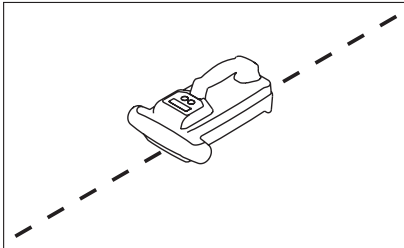

Fig. 10: Orientation of the generator in relation to the line for inductive energizing

The generator is switched off.

1. Position the generator above the line to be located.

The handle must be aligned parallel to the line being located (Fig. 10). The angle between the line and the longitudinal axis of the device must not exceed 15°.



### **CAUTION! Risk of accident in the work area**

Equipment and cables lying on the ground can cause a tripping hazard.

- Secure the entire work area to prevent access by third parties.
- 

2. Switch on the generator.
3. Select a suitable power level.

The line is energized with the selected power.

### **4.2.1.3 Energizing with a cable clamp**

Individual cables can be energized selectively using a cable clamp. This does not require a direct connection to the cable and the cable does not need to be exposed.

Energizing requires a generator and a cable clamp.

---



### **NOTICE! Risk of injury from high voltage**

If the cable clamp is connected to a single core of a power cable, high voltages can occur in the cable clamp. These voltages can lead to shock currents or can destroy the receiver.

- Only use the cable clamp if you are certain that the current in the power cables does not exceed 300 A.
-

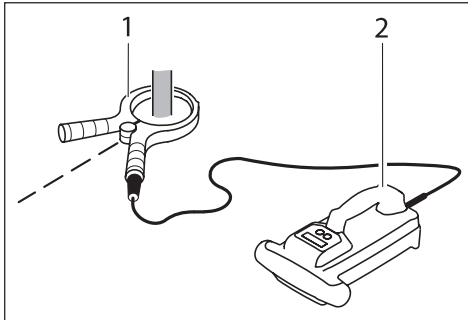

Fig. 11: Arrangement of the devices for energizing with a cable clamp  
1 Cable clamp, 2 Generator

The generator is switched off.

1. Connect the cable from the cable clamp to the generator.
2. Attach the cable clamp.  
Follow the operating instructions for the cable clamp.
3. Switch on the generator.
4. Select a suitable power level. SEWERIN recommends setting a high power for energizing with a cable clamp.

The line is energized with the selected power.

### 4.2.2 Locating a line

The line is energized.

1. Switch on the receiver.
2. Using the Menu key, select active location as the locating method.
3. Hold the receiver vertically downwards.
4. Locate the line. Evaluate the response by the receiver.

---

#### Note:

When locating **inductively energized** lines, it is possible to mistakenly locate the self-field of the generator.

- When locating inductively energized lines, always keep the receiver about 15 m away from the generator.
- 

### Response by the receiver during active location

#### Audio

- Lower tone to the left of the line\*)
- Higher tone to the right of the line\*)
- No tone directly above the line\*)

#### Directional arrows

- Get shorter as you approach the line\*)
- Change into a diamond directly above the line\*)



- Diamond with depth symbol if the receiver is held still directly above the line\*)

#### Field strength

- Maximum directly above the line\*)

#### Gain

- Set automatically by the device

\*) i.e., the line to be located

### 4.2.3 Problems in locating adjacent lines

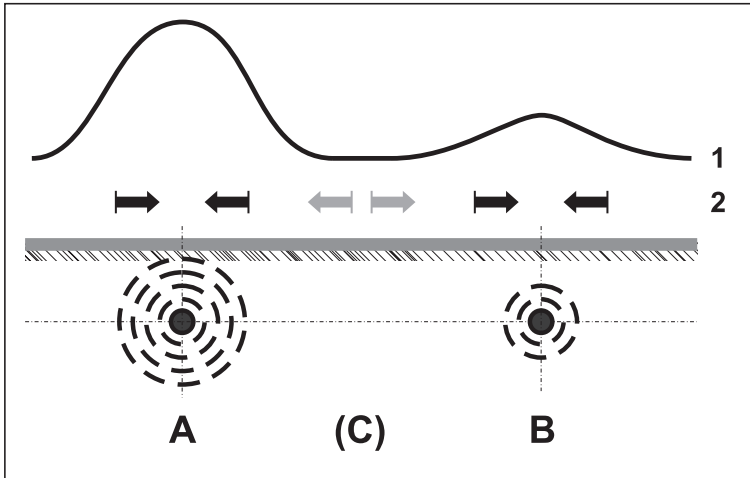

Fig. 12: Locating situation with adjacent lines  
 A Line to be located (galvanically energized), B Additional line,  
 1 Signal curve, 2 Directional arrows

Fig. 12 shows a locating situation with an additional line B close to the line to be located, line A.

Line A is galvanically energized. The signal curve (1) shows a maximum above each line. A lower tone can be heard to the left of each line and a higher tone to the right. No tone can be heard directly above a line.

#### 4.2.3.1 Errors arising from the use of acoustic location alone

Users who use primarily acoustic location can sometimes locate a fictitious line C between line A and line B.

No tone can be heard directly above line C. A higher tone can be heard to the left of C and a lower tone to the right. The user hears that the tones to the left and right of the fictitious line are different. But he fails to notice that the lower and higher tones are transposed.

**4.2.3.2 Tip 1: Check the directional arrows**

If you check the directional arrows on the display, it is not possible to locate a fictional line C.

The directional arrows show the direction in which a line is located. Directly over a line the directional arrows turn into a diamond. As C is not a line, no diamond appears.

**4.2.3.3 Tip 2: Use the PEAK function**

The PEAK function helps to locate the line with the strongest signal by suppressing weaker signals.

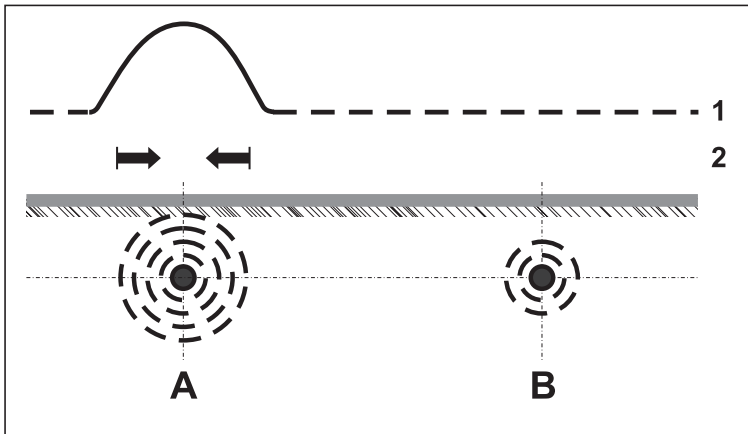

Fig. 13: Same locating situation as in Fig. 12, signal curve with PEAK function

The PEAK function is activated by means of the arrow-down key. You must keep the arrow-down key held down for as long as you wish to use the PEAK function.

### 4.3 Passive location

Passive location uses electromagnetic fields that are already present at a line to be located. Only the receiver is needed for locating.

1. Switch on the receiver.
2. Using the Menu key, select passive location with a particular frequency (50 Hz, 100 Hz, 150 Hz) as the locating method.
3. Hold the receiver vertically downwards and with the handle parallel to the assumed route of the line (Fig. 14).



Fig. 14: Receiver oriented to the assumed route of the line for passive location

4. Locate the line. Evaluate the response by the receiver.

#### Response by the receiver during passive location

- |                       |   |
|-----------------------|---|
| <b>Audio</b>          | <ul style="list-style-type: none"> <li>● Tone level varies with field strength</li> <li>● Stronger signals produce a higher tone</li> <li>● Maximum directly above the line*)</li> </ul>  |
| <b>Field strength</b> | <ul style="list-style-type: none"> <li>● Maximum directly above the line*)</li> </ul>   |
| <b>Gain</b>           | <ul style="list-style-type: none"> <li>● Must be set manually by the user</li> <li>● High gain &gt; high signal sensitivity: locating can be carried out further away from the generator</li> <li>● Low gain &gt; low signal sensitivity: may reduce overloading</li> </ul> |

\*) i.e., the line to be located

### 4.4 Locating errors

Interference fields are the most common sources of error. Interference fields can distort the electromagnetic fields along the line, thus producing erroneous location results. This can apply to both the position and the depth of the line.

Electromagnetic fields that are too weak or distorted can also lead to incorrect location results. Distorted fields occur, for example, when other lines cross the line to be located or at junctions and bends.

If there are lines close beside or below one another in parallel, the receiver will only be able to determine one line. The line determined is a fictitious line between those that are actually present.



## 5 Troubleshooting

### 5.1 Problems with the receiver

Problem	Possible cause	Corrective action
Cannot switch on receiver	Remaining battery capacity too low	<ul style="list-style-type: none"> <li>● Change disposable batteries</li> </ul>
	Power supply interrupted	<ul style="list-style-type: none"> <li>● Check battery contact</li> </ul>
Receiver does not respond when switched on	Receiver faulty	<ul style="list-style-type: none"> <li>● Check that the receiver is working correctly: Switch on the generator and receiver &gt; Hold receiver aerial towards the generator from approx. 2.5 m &gt; Receiver must receive a signal of the same frequency</li> </ul>
	Remaining battery capacity too low	<ul style="list-style-type: none"> <li>● Change disposable batteries</li> </ul>
Display blank	Contrast setting too low	<ul style="list-style-type: none"> <li>● Open menu &gt; increase contrast</li> </ul>
No acoustic signal audible	Tone switched off or volume setting too low	<ul style="list-style-type: none"> <li>● Increase volume</li> </ul>
Display shows unusually fluctuating values	Interference fields present	<ul style="list-style-type: none"> <li>● Eliminate interference fields: e.g. switch off computers, monitors, light dimmers, industrial appliances</li> </ul>
Active location: Field strength overloaded (with minimum gain)	Receiver too close to generator	<ul style="list-style-type: none"> <li>● Move receiver away from generator</li> </ul>

## 5.2 Problems with the generator

Problem	Possible cause	Corrective action
Cannot switch on generator	Remaining battery capacity too low	<ul style="list-style-type: none"> <li>● Change disposable batteries</li> </ul>
Generator does not transmit when switched on	Generator faulty	<ul style="list-style-type: none"> <li>● Check that the generator is working correctly: Switch on the generator and receiver &gt; Hold receiver aerial towards the generator from approx. 2.5 m &gt; Receiver must receive a signal of the same frequency</li> </ul>
	Remaining battery capacity too low	<ul style="list-style-type: none"> <li>● Change disposable batteries</li> </ul>
Galvanic energizing not working	Line is not electro-conductive	<ul style="list-style-type: none"> <li>● <b>UT 830</b> is unsuitable &gt; use a different device or locating method</li> </ul>
	Electrical circuit interrupted	<ul style="list-style-type: none"> <li>● Check cable set connection</li> <li>● Move earthing spike</li> <li>● Replace cable set</li> </ul>
	Not enough or no current flowing through the line to be located	
	Cable set faulty	<ul style="list-style-type: none"> <li>● Replace cable set</li> </ul>
	Cable set not correctly connected	<ul style="list-style-type: none"> <li>● Check cable set connection</li> </ul>
Inductive energizing not working	Generator not positioned correctly above the line to be located	<ul style="list-style-type: none"> <li>● Reposition the generator</li> </ul>
Generator switches off during the locating process	Insufficient power supply	<ul style="list-style-type: none"> <li>● Choose a lower power level</li> <li>● Change disposable batteries</li> </ul>

## 6 Appendix

### 6.1 Technical data

#### 6.1.1 UT 830 R receiver

##### Device data

Dimensions (W x D x H)	213 x 307 x 781 mm
Weight	2.3 kg

##### Certificates

Certificate	CE
-------------	----

##### Features

Display	Graphic liquid crystal display with LED back-light
Operation	Membrane keypad with 4 keys

##### Operating conditions

Operating temperature	-20 °C – +50 °C
Storage temperature	-25 °C – +60 °C
Humidity	10 % – 90 % r.h., non-condensing
Atmospheric pressure	950 – 1100 hPa
Protection rating	IP65
Non-permitted operating environments	in potentially explosive areas

##### Power supply

Power supply	2 cells, type: mono D, either: – Disposable batteries (as delivered) – Rechargeable batteries
Operating time, typical	75 h (disposable batteries)

##### Locating

Receiving frequency	<ul style="list-style-type: none"> <li>● active frequency: 83.0775 kHz</li> <li>● passive frequencies: 50/60 Hz 100/120 Hz 150/180 Hz</li> </ul>
Location depth	maximum 8 m Error rate: ±5 % up to 3 m

### 6.1.2 UT 830 T generator

#### Device data

Dimensions (W x D x H)	216 x 282 x 142 mm
Weight	2.3 kg

#### Certificates

Certificate	CE
-------------	----

#### Features

Display	Graphic liquid crystal display with LED back-light
Operation	Membrane keypad with 2 keys

#### Operating conditions

Operating temperature	-20 °C – +50 °C
Storage temperature	-25 °C – +60 °C
Humidity	10 % – 90 % r.h., non-condensing
Atmospheric pressure	950 – 1100 hPa
Protection rating	IP65
Non-permitted operating environments	in potentially explosive areas

#### Power supply

Power supply	6 cells, type: mono D, either: – Disposable batteries (as delivered) – Rechargeable batteries
Operating time, maximum	150 h with disposable batteries at power level 1
Operating time, typical	80 h with disposable batteries at power level 2

#### Locating

Transmitting frequency	83.0775 kHz
Transmitting power	1 W, 3 power levels

## 6.2 Accessories and consumables

### Accessories

Part	Order number
UT 830 cable set	9083-0005
Earthing spike 535lg	4001-0038
UT 830 cable clamp 3"	9083-0003
UT 830 cable clamp 5"	9083-0004

### Consumables

Part	Order number
Battery, mono, LR20	1353-0003

Other accessories and consumables are available for the product. Please contact our SEWERIN sales department for further information.

## 6.3 EC Declaration of Conformity

Hermann Sewerin GmbH hereby declares that the UT 830 fulfils the requirements of the following directives:

- 2004/108/EC

The complete declaration of conformity can be found online.

## 6.4 Advice on disposal

The European Waste Catalogue (EWC) governs the disposal of appliances and accessories.

Description of waste	Allocated EWC waste code
Device	16 02 13
Disposable battery, rechargeable battery	16 06 05

### End-of-life equipment

Used equipment can be returned to Hermann Sewerin GmbH. We will arrange for the equipment to be disposed of appropriately by certified specialist contractors free of charge.

## 7 Index

### C

Contrast 9

### D

Depth

Measuring 5

Diamond 22

Directional arrow 6

Display

Elements 6

Symbols 7

### E

Energizing

Cable clamp 15, 20

Galvanic 15, 18

Inductive 15, 19

### F

Field strength

Graphical 6

Numerical 6

Frequency

Passive 10

### G

Gain

Graphical 6

Increasing 5

Numerical 6

Reducing 5

Generator

Battery change 15

Power supply 15

Troubleshooting 28

### I

Info 10

### L

Line

Active location 22

Line location 17

Locating

Active 11, 17

Adjacent lines 23

Errors 23, 26

Passive 11, 25

Problems 23

Locating modes 11

### M

Menu 8

Exiting 8

Opening 8

Menu item

Exiting 8

### O

Operating mode 15

### P

PEAK function 24

Opening 5

PowerSetup 10

### R

Receiver 4

Battery change 11

Display 6

Power supply 11

Troubleshooting 27

### S

Settings 8

**T**

Transmitter *see* Generator

**U**

Units 9

Use

    Intended 2

UT 830 R *see* Receiver

UT 830 T *see* Generator

**V**

Volume 4

    Changing 5



Hermann Sewerin GmbH  
Robert-Bosch-Straße 3  
33334 Gütersloh, Germany  
Tel.: +49 5241 934-0  
Fax: +49 5241 934-444  
www.sewerin.com  
info@sewerin.com

SEWERIN IBERIA S.L.  
Centro de Negocios Eisenhower  
Avenida Sur del Aeropuerto de  
Barajas 24, Ed. 5 Of. 2C  
28042 Madrid, España  
Tel.: +34 91 74807-57  
Fax: +34 91 74807-58  
www.sewerin.es  
info@sewerin.es

SEWERIN SARL  
17, rue Ampère - BP 211  
67727 Hoerdt Cedex, France  
Tél. : +33 3 88 68 15 15  
Fax : +33 3 88 68 11 77  
www.sewerin.fr  
sewerin@sewerin.fr

Sewerin Sp.z o.o.  
ul. Annopol 3  
03-236 Warszawa, Polska  
Tel.: +48 22 519 01 50  
Faks: +48 22 519 01 51  
Tel. kom.: +48 501 879 444  
www.sewerin.pl  
info@sewerin.pl

Sewerin Ltd  
Hertfordshire  
UK  
Phone: +44 1462-634363  
www.sewerin.co.uk  
info@sewerin.co.uk

Sewerin USA LLC  
2835 Haddonfield Road  
Pennsauken, NJ 08110-1108  
Phone: +1 215-852-8355  
Fax: +1 856-662-7070  
www.sewerin.net  
sewerin-usa@sewerin.net



# EDENBROS, LLC

## Products:

1. Pipe & Cable Locators
2. Metal Detectors
3. Sewer Cameras
4. Duct Rodders & Sondes
5. Leak Noise Correlators
6. Leak Listeners
7. Noise Loggers
8. Gas Detectors
9. Ground Penetrating Radar
10. Data Loggers
11. Tools
12. Software

## Services:

1. CCTV Inspection
2. Leak Detection
3. Utility Location
4. Fault Finding
5. Ground Penetrating Radar
6. Thermal Imaging

Used Equipment & Ex-Demo  
Items always available.

Check our website for a current  
listing:

[www.edenbros.com](http://www.edenbros.com)

**EDENBROS, LLC**  
PO BOX 247  
SAINT JAMES, MO 65559

Tel: 800-526-5246  
Fax: 800-807-9368  
Web: [www.edenbros.com](http://www.edenbros.com)

