

## **P350 flexitrac**

Pearpoint's advanced crawler-based video inspection system



Operation Manual | Issue 5 | July 2011

# P350 flexitrax™ system



# Preface

## Before you begin

Please read this operation manual before attempting to use the P350 flexitrax system. Note that this manual and all its contents are subject to change. Pearpoint products are under continuous development.

Pearpoint reserves the right to modify any product, including this manual, without notice and some product changes may have taken place after this user manual was published.

Contact your local Pearpoint dealer or visit [www.radiodetection.com](http://www.radiodetection.com) for the latest information about the P350 flexitrax product family, including all accessories, documentation and software updates.

## Important safety notices

Please observe all safety notices and warnings in this manual before operating any Radiodetection or Pearpoint product.







## Warnings, Cautions and Notes

**WARNING!** Warnings alert you to possible personal injury.

**CAUTION:** Cautions alert you to possible equipment damage.

**NOTE:** Notes contain useful information.

## Key to symbols used

-  General Warning: Refer to Manual for specific instruction or advice.
-  Electrical Hazard: Observe safe practices and exercise extreme caution.
-  Heavy object: Additional care must be taken when lifting.
-  Biohazard: Disinfect after use. Wear appropriate personal protective equipment (PPE).
-  Hot Surface: Allow to cool or use appropriate protection when handling.
-  Pinch point: Keep fingers or loose clothing clear.

## General

Pearpoint has taken care to provide the necessary information in this manual for the safe installation, operation, maintenance and disposal of this equipment. However, a risk assessment should be performed prior to commencing work as it may highlight additional safety issues specific to the application.

## Installation

The P350 flexitrax, including its component parts is heavy. If available, use the wheels to assist transport. Observe heavy-lifting safety practices when lifting any component of this system. Refer to the specifications in Appendix 9.9 for a description of the system's dimensions and weights.

If mains operated equipment is connected to the system then the external equipment must be earthed in accordance with the manufacturer's instructions. Failure to comply with this may cause the unit to become live and a **LETHAL HAZARD**.

## Generator Selection

Pearpoint strongly recommends the use of generator equipment with Inverter type outputs. This results in the best possible quality of supply voltage to the P350 system over varying load conditions. To power the P350 system in isolation (in all configurations) requires an inverter output rated at 1.2kVA, additional electrical loads connected to the same generator will increase the overall required rating accordingly.

Generator equipment with AVR type outputs may be suitable for use if the minimum requirements of generator loading for AVR operation are met under all operational circumstances; this is one reason why inverter output equipment is highly recommended. The minimum load the P350 system provides can be as low as 75VA. AVR equipment operated below its minimum loading can lead to loss of voltage regulation that could cause damage to the P350 system. Additional high power loads (such as a water heater or air-conditioner) on an AVR generator can also lead to voltage fluctuations that could exceed the maximum ratings of the P350 system.

Generator equipment that does not employ voltage regulation techniques outlined above (e.g. condenser output or synchro-converter output) must not be used with the P350 system as damage to the P350 system from unregulated voltages is likely.

If in doubt regarding generator output selection, voltage stability or installation of the generator into a vehicle, consult a qualified electrician and/or your generator supplier.

## Operation guidelines

Please observe your company, region or country's Standard Code of Practice for surveying underground utilities with CCTV equipment, if applicable, when using this equipment.

Always carry out a risk assessment of the site to be inspected. This equipment is **NOT** approved for use in areas where hazardous gasses may be present.

 Foul water systems can be a source of serious biological hazards. Wear appropriate protection when handling the P350 flexitrax.

 The camera will get hot during use. This is normal. Exercise care when handling the camera at all times.

 System components must **NOT** be connected/ disconnected when the power is on.

Take care to ensure that video and power cables do not get entangled in the drum. Cables ties are recommended and will not impede system performance.

Always store the P350 flexitrax system in a clean and dry environment.

## Safety precautions

Ensure that standard safety precautions for working in hostile environments are followed.

The flexitrax Power Supply Unit (PSU) is designed to reduce hazards from electric shock provided that proper operating procedures are followed. The P350 flexitrax system requires connection to a protective earth; if in doubt, consult a qualified electrician.

Electrical equipment is factory tested for electrical safety. Routine inspection is recommended (and may be required by law) to maintain this level of protection. If you are unsure, contact your local safety authority for advice.

The flexitrax Power Supply Unit has a number of ventilation slots around the casing that are designed to maximize air circulation and reduce heat. There is a potential fire risk if the build-up of heat is prevented from escaping. Under no circumstances are these ventilation slots to be covered or blocked.

If using a generator follow the manufacturer's instructions on load connection and sequencing. In the absence of these instructions the following guidelines should be used:

- When starting the generator; ensure that all electrical loads, including the P350 are switched off before starting the generator. Allow the generator to stabilise before connecting any electrical loads or switching on the P350.

- When stopping the generator; ensure all electrical loads, including the P350 are switched off before stopping the generator.
- Starting or stopping a generator whilst the P350 system is connected and the main switch is in the On position could lead to damage to the P350 system or the generator.

Always use heavy duty industrial gloves when handling cable which is being withdrawn from a sewer.

Always ensure that cabling is properly connected.

A portable generator can be a hazard if not properly operated. Always follow the manufacturer's instructions.

Always transport a generator with the minimum amount of fuel in the tank.

Always switch the system on and off using the main system switch.

Never lower crawlers or other heavy equipment into manholes while personnel are working in the manhole.

 To avoid risk of burns do not touch cameras/ lightheads when they are switched on or immediately after switch off. Leave ample time for them to cool before handling.

 The camera's LEDs are very powerful. Do not look directly at the LEDs or point them at other people.

## Maintenance

 Clean and sanitize the P350 flexitrax system at regular intervals and after conducting an inspection.

Always keep all connectors covered with their protective caps when the equipment is not in use.

Do not dismantle any component of this system unless directed by this operation manual. Dismantling components not specified by this manual may void the product warranty.

Pearpoint recommends that only authorized service centers carry out service of this product. Service elsewhere will void the warranty.

For information regarding any service needs, please visit [www.radiodetection.com](http://www.radiodetection.com) or contact your local Radiodetection or Pearpoint representative or dealer.

## Disposal

Do not dispose of this product in municipal waste facilities. Please check local regulations for disposal of electronic products.

Radiodetection complies with the requirements of 2002/96/EC Waste Electrical and Electronic Equipment.

## Declaration of Conformity

**We: Radiodetection Limited**  
**Western Drive**  
**Bristol**  
**BS14 0AF**

Declare that the products listed below satisfy the essential requirements of the following Council Directives:

- 2004/108/EC, relating to Electromagnetic Compatibility. (EMC)
- 2006/95/EC, relating to Electrical Equipment within certain voltage limits (LVD)
- 1999/5/EC, Radio & Telecommunications Terminal Equipment Directive (R&TTE)

### P350 "flexitrax" inspection system

Comprising modules from the following list and ancillary equipment listed in the technical file.

Component	Part Number	Description
Command module	10/P350-CMOD	P350 Command Module
Drums	10/P350-DRUM-P- xxx	P350 Powered Drum, 100m, 150m, 250m
	10/P350-DRUM-M-xxx	P350 Manual Drum, 100m, 150m, 250m
PSU	10/P350-PSU-M	P350 PSU for Manual Drum
Crawlers	10/P354	P350 100mm (4") Crawler
	10/P356	P350 150mm (6") Crawler
Cameras	10/P350-CAM-FW- yyyy	P350 PAL/NTSC Forward View Camera
	10/P350-CAM-PT- yyyy	P350 PAL/NTSC Pan & Tilt Camera
	10/P350-CAM-PTZ-yyyy	P350 PAL/NTSC Pan & Tilt, Zoom Camera

The following standards have been used in the evaluation

- EN 61010-1: 2001 Safety requirements for electrical equipment for measurement control and laboratory use.
- EN61326-2-1: 2006 Electrical equipment for measurement, control and laboratory use. EMC Requirements.
- EN 301 489-17: 2000 ElectroMagnetic Compatibility and Radio Spectrum Matters (ERM);  
ETSI TR 102 070-1 Scenario 2 has been applied for integration of a type approved Bluetooth module

The Technical Construction File has been drawn up to demonstrate compliance with the essential requirements of these Directives and is kept at the above address

Signed D.A.F. Ranfield

Date: 04/12/2008

Director

Radiodetection Ltd  
Western Drive  
Bristol BS14 0AF, UK  
Tel: +44 (0) 117 976 7776  
Fax: +44 (0) 117 976 7775  
email:sales.uk@radiodetection.spx.com  
http://www.radiodetection.com



**Radiodetection**  
AN SPX COMPANY

Certificate No. TD-2008-001-01

## Compliance

### EU Compliance

This equipment complies with the following EU Directives.

- Low Voltage Directive: 2006/95/EC
- Machinery Directive: 98/37/EC
- EMC Directive: 2004/108/EC
- R&TTE Directive: 99/5/EC

### FCC Compliance Statement

This equipment complies with Part 15 of the FCC Rules. Operation is subject to the following two conditions:

- The equipment may not cause harmful interference.
- The equipment must accept any interference received, including interference that may cause undesired operation.

**Note:** This equipment has been tested and found to comply with the limits for a Class A digital device pursuant to Part 15 of the FCC Rules. These limits are designed to provide reasonable protection against harmful interference when the equipment is operated in a commercial environment. This equipment generates, uses, and can radiate radio frequency energy and, if not installed and used in accordance with the manufacturer's instruction manual, may cause harmful interference with radio communications. Operation of this equipment in a residential area is likely to cause harmful interference, in which case you will be required to correct the interference at your own expense.

Modifications: Any modifications made to this equipment that are not approved by Pearpoint may void the authority granted to the user by the FCC to operate this equipment.

### Industry Canada compliance statements

ICES-003 Class A Notice:

This Class A digital apparatus complies with Canadian ICES-003.

Avis NMB-003, Classe A:

Cet appareil numérique de la classe A est conforme à la norme NMB-003 du Canada.

### Bluetooth transmitter

Contains Transmitter Module FCC ID: PI409B / IC: 1931B-BISMPA33.

## Trademarks

flexitrax, flexiprobe, FlexiSight and RD7000DL are trademarks of Radiodetection Ltd, all rights reserved.

Pearpoint is a trademark owned by Radiodetection Ltd - SPX Corporation.

The Bluetooth word, mark and logo are registered trademarks of Bluetooth SIG, Inc. and any use of such trademarks by Radiodetection is under license.

Windows, Windows XP, Windows Vista, Windows Media Player, Windows Movie Maker, Microsoft Word and Microsoft Office 97 are trademarks of Microsoft Corporation, all rights reserved.

QuickTime, Mac, Mac OS, Finder, iMovie and Final Cut Pro are trademarks of Apple Inc., registered in the U.S and other countries.

Other trademarks or registered trademarks mentioned in this document belong to their respective owners.

## Disclaimer

Any third-party products (including hardware, software and services) mentioned in this manual are for instructional purposes only and is not an endorsement by Radiodetection Ltd, Pearpoint and SPX Corporation.

Radiodetection Ltd does not accept any liability for loss of data or damage to equipment when using any third-party products.

## Copyright statement

Copyright 2011 Pearpoint Ltd. / Radiodetection Ltd – SPX Corporation. All rights reserved.

Radiodetection is a subsidiary of SPX Corporation.

SPX, Radiodetection and flexitrax are trademarks of Radiodetection Ltd. and SPX Corporation. Due to a policy of continued development, we reserve the right to alter or amend any published specification without notice.

This document may not be copied, reproduced, transmitted, modified or used, in whole or in part, without the prior written consent of Radiodetection Ltd.

## Training

Pearpoint provides training services for most Pearpoint products. Our qualified instructors will train equipment operators or other personnel at your preferred location or at Pearpoint headquarters.

For more information go to [www.radiodetection.com](http://www.radiodetection.com) or contact your local Pearpoint representative.

# Table of contents

<b>Preface</b>	<b>i</b>		
Before you begin	i		
Important safety notices	i		
Warnings, Cautions and Notes	i		
Key to symbols used	i		
General	i		
Installation	i		
Operation guidelines	i		
Safety precautions	i		
Maintenance	ii		
Disposal	ii		
Compliance	iv		
EU Compliance	iv		
FCC Compliance Statement	iv		
Industry Canada compliance statements	iv		
Bluetooth transmitter	iv		
Trademarks	iv		
Disclaimer	iv		
Copyright statement	iv		
Training	iv		
<b>Section 1 – Introduction</b>	<b>1</b>		
1.1 About this manual	1		
1.2 Overview	1		
1.3 Safety notices	1		
1.4 Latest updates and information	1		
<b>Section 2 – System overview</b>	<b>2</b>		
2.1 Command module	2		
2.1.1 Keypad	2		
2.2 Cable drums	4		
2.2.1 Powered drum	4		
2.2.2 Manual drum	4		
2.2.3 External PSU (manual system only)	4		
2.2.4 Link cables	4		
2.3 Crawlers and Crawler cameras	6		
2.4 Pushrod reels and cameras	6		
2.5 Accessories	6		
<b>Section 3 – System assembly</b>	<b>7</b>		
3.1 Crawler and accessories	7		
3.1.1 Crawler weight (P354 Only)	7		
3.1.2 Wheels and tires	8		
3.1.3 Cameras	10		
3.1.4 Elevator	10		
3.1.5 Auxiliary Lighthouse	11		
3.1.6 Crawler connection	12		
3.2 Crawler deployment tools	12		
3.3 Manual drum and external PSU	13		
3.4 Powered drum	13		
3.5 Command module	13		
3.5.1 Mounting	13		
3.5.2 Power, data and video	13		
3.5.3 Compact Flash card	13		
3.5.4 Keyboard	13		
3.5.5 Headset	13		
3.6 External video equipment	13		
<b>Section 4 – Command module and system setup</b>	<b>14</b>		
4.1 Overview	14		
4.2 Powering up	14		
4.3 Getting help	14		
4.4 Welcome screen	14		
4.5 On-screen display (OSD)	15		
4.5.1 Customizing the OSD	15		
4.5.2 OSD layouts	15		
4.5.3 System menu timeout	16		
4.5.4 Text appearance	17		
4.6 System Menu	17		
4.6.1 General navigation and text entry	17		
4.6.2 SETUP menu	18		
4.6.3 CARD menu	20		
4.6.4 DVR menu	20		
4.6.5 SCRNM menu	22		
4.6.6 DRIVE	22		
4.6.7 TEXT and Report menu	23		
4.7 Command module settings	24		
4.8 Drum and reel settings	24		
4.8.1 Drum type and cable length	24		
4.9 Crawler and camera settings	24		
4.9.1 Crawler wheel size	24		
4.9.2 Numeric inclinometer	24		
4.9.3 Camera settings	25		
4.10 Company details	25		
4.11 Splash and video title screens	26		
4.11.1 Splash screens	26		
4.11.2 Video title screen	26		
4.12 Ethernet configuration	26		
4.13 Restoring factory settings	27		

<b>Section 5 – System operation</b>	<b>28</b>		
5.1 Emergency stop	28		
5.2 Deployment	28		
5.2.1 Before deployment	28		
5.2.2 Using the crawler deployment tool	28		
5.2.3 Cable and manhole rollers	30		
5.2.4 Distance counter and Auto Stop point	31		
5.2.5 Sonde	31		
5.3 Driving crawlers	31		
5.3.1 System stop	31		
5.3.2 Drive mode and OSD	31		
5.3.3 Mimic	33		
5.3.4 Navigating with advanced mimic	34		
5.3.5 Pitch profiler	34		
5.3.6 Manual system	36		
5.3.7 Powered drum	36		
5.3.8 Steering (P356 crawler only)	37		
5.3.9 Tractor power	38		
5.4 Video recording	38		
5.5 Still pictures	38		
5.6 Camera controls	38		
5.6.1 Lights	38		
5.6.2 Auxiliary lighthead	38		
5.6.3 Focus	39		
5.6.4 Pan	39		
5.6.5 Tilt or rotate.	39		
5.6.6 Center	39		
5.6.7 Zoom	39		
5.7 Digital image controls	39		
5.7.1 Pan	39		
5.7.2 Rotate	39		
5.7.3 Zoom	39		
5.8 Pendant controller	40		
5.9 Retrieving the crawler	43		
<b>Section 6 – File management and Transfer</b>	<b>44</b>		
6.1 CARD menu	44		
6.1.1 Destination folder	44		
6.1.2 Reports	45		
6.1.3 Card status	45		
6.1.4 Formatting the card	45		
6.2 Supported card types	45		
6.3 File browser	46		
6.3.1 Organizing your work	46		
6.3.2 Filename structure	46		
6.3.3 Copying files	46		
6.3.4 Moving files and folders	47		
6.3.5 Renaming files and folders	47		
6.3.6 Deleting files and folders	47		
6.3.7 Creating folders	47		
6.3.8 Sending a file with Bluetooth®:	47		
6.3.9 Information	47		
6.4 Viewing Pitch Log	47		
6.5 Viewing JPEG pictures	48		
6.6 Playing videos	48		
6.6.1 Screen captures	49		
6.7 USB connections	49		
6.6.1 Disconnecting	49		
6.8 Bluetooth®	50		
6.8.1 Pairing	50		
6.8.2 Transferring files	50		
<b>Section 7 – Inspection reports and text pages</b>	<b>52</b>		
7.1 About reports and pages	52		
7.2 Defect Codes	52		
7.3 Video text pages	52		
7.3.1 Browsing text pages	52		
7.3.2 Overlay selected page	52		
7.3.3 Remove text page	52		
7.3.4 Editing text pages	52		
7.3.5 Changing text appearance	53		
7.4 Reports	53		
7.4.1 Creating a new report	54		
7.4.2 Client	54		
7.4.3 Company	54		
7.4.4 Freetext	55		
7.4.5 Observations	55		
7.4.6 Photos	55		
7.4.7 Site page	56		
7.4.8 Survey	56		
7.5 Editing reports	56		
7.6 Deleting reports	57		
7.7 Viewing and printing reports	57		
7.7.1 Folder structure	57		
7.7.2 Browsing and printing	57		
7.8 Exporting reports to Word	58		
7.8.1 Conversion requirements	58		
7.8.2 Conversion overview	58		
7.8.3 Conversion troubleshooting	59		
7.8.4 Customizing the Word template	59		
<b>Section 8 – Digital Video</b>	<b>60</b>		
8.1 Video Specification	60		
8.2 Video quality Settings	60		
8.2.1 Custom quality settings	61		
8.3 Advanced video options	61		



8.3.1 INPUT	61	<b>List of figures and tables</b>	
8.3.2 DESTN	62	Figure 2.1: Command module	3
8.3.3 FNAME	62	Figure 2.2: Command module rear view	3
8.4 Video playback	62	Figure 2.3: Command module I/O panel	3
8.4.1 Command module playback	62	Figure 2.4: Command module keypad	3
8.4.2 Computer playback	62	Figure 2.5: Powered drum with command module installed	5
8.5 Distributing your recordings	63	Figure 2.6: Manual drum	5
8.5.1 Producing a DVD video	64	Figure 2.7: Front and rear connection panels (Common to powered drum and external PSU)	5
8.5.2 Supported digital video files	64	Figure 2.8: External PSU	5
8.5.3 Unsupported digital video files	65	Figure 2.9: Link cables	5
8.5.4 Using data CDs, DVDs and USB flash drives	65	Figure 2.10: P354 crawler with P350-CAM-FW camera installed	6
8.6 Converting digital videos	66	Figure 2.11: P356 crawler with P350-CAM-PTZ camera installed	6
8.6.1 System requirements	66	Figure 3.1: P356 crawler assembly	7
8.6.2 Conversion software for Windows	66	Figure 3.2: Connecting various tires	8
8.6.3 Conversion software for Mac OS X	66	Figure 3.3: Crawler configurations (opposite)	8
8.7 Advanced video editing	67	Figure 3.4: Connecting a fixed view camera	10
8.7.1 FlexiSight	67	Figure 3.5: Fixed view camera	10
8.7.2 DV	67	Figure 3.6: Pan and tilt camera	10
<b>Section 9 – Appendix</b>	<b>68</b>	Figure 3.7: Pan, tilt and zoom camera	10
9.1 Shortcuts	68	Figure 3.8: P350 camera elevators	11
9.2 Care and maintenance	69	Figure 3.9: Adjustable elevator	11
9.2.1 Terminals	69	Figure 3.10: Installing the large adjustable elevator	11
9.2.2 Cleaning the system	69	Figure 3.11: Adjusting the large adjustable elevator	11
9.2.3 Storing the system	69	Figure 3.12: Auxiliary lighthouse	11
9.3 Upgrading software	69	Figure 3.13: Strain relief clamp and spring guard	12
9.4 Crawler cable re-termination	71	Figure 4.1: Welcome Screen	14
9.5 Cable drum replacement	72	Figure 4.2 System onscreen display (OSD)	15
9.5.1 Disassembly	72	Figure 4.3: Normal OSD layout	16
9.5.2 Assembly	73	Figure 4.4: TV OSD layout	16
9.5.3 Replacing cable	73	Figure 4.5: Custom OSD layout	16
9.6 AVC Video licence	74	Figure 4.6: Main screen showing top-level system menu	17
9.7 Defect codes text file	74	Table 4.1: Setup menu schema.	18
9.7.1 Text encoding	74	Table 4.2: CARD menu schema	20
9.8 Specifications	75	Table 4.3: DVR menu schema	21
9.8.1 Environmental specifications	75	Table 4.4 Screen menu schema	22
9.8.2 Command module	75	Table 4.5: Drive menu schema	22
9.8.3 Cable Drums	76	Table 4.6: TEXT menu schema	23
9.8.4 Crawlers	76	Figure 4.7 Company information menu	25
9.8.5 Cameras	76	Figure 4.8: Video title page	26
9.8.6 Auxiliary lighthouse	77	Figure 4.9: Ethernet configuration	27
9.8.7 Elevators	77	Figure 5.1: Downhole cable rollers	28
9.8.8 Pendant Controller	77	Figure 5.2: Crawler grab kit	28
9.8.9 Approvals	77		

Figure 5.3: Crawler grab setup	29	Figure 9.7: Powered drum with slave side panel and drum support channel removed	72
Figure 5.4: Crawler grab and crawler	29	Figure 9.8: Adjusting the drive train	73
Figure 5.5: Crawler grab and crawler with attached elevator	30	Figure 9.9: Cable layering sprocket and follower	73
Figure 5.6: Crawler grab in the closed position	30	Figure 9.10: Cable layering mechanism	73
Figure 5.7: Lowering the crawler into a manhole	30	Figure 9.11: Cable drum cassette	73
Figure 5.8: Using cable rollers	30	Table 9.6: Defect_codes.txt structure	74
Figure 5.9: Driving mode OSD	32		
Figure 5.10: Basic mimic	33		
Figure 5.11: Steering mimic	33		
Figure 5.12: Pan and tilt mimic with steering bar	33		
Table 5.1: Advanced mimic controls	34		
Figure 5.13: Advanced mimic controls	35		
Figure 5.14: Crank handle for powered drum	37		
Figure 5.15: Pendant controller	40		
Figure 6.1 Compact Flash card warning page	44		
Figure 6.2: CARD menu	44		
Figure 6.3: Compact Flash card status page	45		
Figure 6.4: Compact Flash browser	46		
Figure 6.5: File browser delete and show screen	47		
Figure 6.6: Windows USB hub manager	49		
Figure 6.7: <i>Bluetooth</i> <sup>®</sup> menu	50		
Figure 6.8: <i>Bluetooth</i> <sup>®</sup> device selection page	51		
Figure 6.9: Mac OS X Sharing preferences	51		
Figure 7.1: Text and Report menu	52		
Figure 7.2 Video text editing page	53		
Figure 7.3: Report menu	53		
Figure 7.4: Report pages	54		
Figure 7.5: Viewing reports in Internet Explorer	57		
Figure 7.6: Report Navigation	58		
Figure 7.7: FlexiSight Report select box	58		
Table 8.1: Video Quality profiles	60		
Figure 8.1: DVR Record settings menu	60		
Figure 8.2: Advanced video settings menu	60		
Figure 8.3: Video playback on Windows XP using VLC media player	63		
Figure 8.4: 4:3 aspect ratio video space usage	63		
Table 9.1: Miscellaneous commands and shortcuts	68		
Table 9.2: Crawler commands and shortcuts	68		
Table 9.3: Camera commands and shortcuts	68		
Table 9.4: Video commands and shortcuts	69		
Figure 9.1: Software Versions info page	69		
Figure 9.2: Camera info page	70		
Figure 9.3: Crawler info page	70		
Figure 9.4: Drum info page	71		
Figure 9.5: Command module info page	71		
Figure 9.6: Drum cassette replacement (exploded)	72		

# Section 1 – Introduction

## 1.1 About this manual

This manual provides comprehensive operating instructions for the P350 flexitrax™ pipeline video inspection system. Before attempting to operate the P350 flexitrax system it is very important that you read this manual, noting all safety warnings and procedures in the Preface, Section 1.3 and throughout the rest of the manual.

Once you have read this manual, it is recommended that you retain it for reference purposes. A printed version of this manual is available on request. Please contact your local Pearpoint representative for more information. The rest of the manual is detailed as follows.

Section 2 includes annotated illustrations of the command module, powered and manual drums and selected accessories.

Section 3 provides a detailed guide to assembling the system ready for conducting inspections.

Section 4 provides a comprehensive introduction to using and configuring the command module.

Section 5 introduces the basics of pipeline inspections and describes how to deploy and drive the crawler, create video recordings and control the camera during an inspection. Section 5 also details retrieving the crawler safely once the inspection is concluded.

Section 6 introduces the Compact Flash card browser and provides a detailed guide to managing your survey files.

Section 7 introduces the report writing function and shows you how to view reports or convert them to Microsoft Word format. Section 7 also details the ability to edit and display system text pages.

Section 8 provides a comprehensive guide to digital video options and settings. Section 8 also includes a guide to converting and distributing videos for playback on computers and other video equipment.

Section 9 is an appendix that includes reference and other important information as well as instructions on caring for and maintaining your P350 system.

## 1.2 Overview

The P350 flexitrax is an advanced pipeline video inspection system that is ideal for a broad range of applications. This system allows operators to identify and document pipeline faults using the latest in digital video recording technology.

The P350 flexitrax is a fully modular system; the command module can drive any combination of drums, cameras and crawlers and is also compatible with the P330+ and P340 flexiprobe™ range of pushrod reels and cameras.

## 1.3 Safety notices

Caution must be taken when conducting any pipeline or draining system inspection. Please observe all safety warnings located in the Preface and throughout this operation manual.

Before you attempt to operate the P350 flexitrax system, it is recommended that you familiarize yourself with any additional health and safety requirements that may be defined by company policy and any applicable local or national laws. Contact your company's or local government's health and safety officer for further information.

## 1.4 Latest updates and information

Pearpoint may have released new system software, user documentation or other information after you purchased your system.

You can download the latest software, documentation and application notes from **[www.radiodetection.com](http://www.radiodetection.com)**.

For more information about checking and upgrading your system's software, please refer to Appendix 9.3.

# Section 2 – System overview

## 2.1 Command module

The command module acts as the controller and digital video recorder and playback device. Video is displayed on an 8" industrial LCD. Video, pictures and inspection reports are stored on a compatible high-speed Compact Flash card.

1. On/Off Switch: This switch only works when the unit is powered by a DC source connected to the power socket.
2. Keypad and function keys: Allows the operator to control the system, select functions and edit text entries.
3. Keyboard: Provides enhanced text entry capabilities and shortcuts to access system functions.
4. Display: LCD Screen shows video, images and various on-screen system information.
5. Link Cable Socket: To connect the pushrod reel, powered drum or manual external PSU to the command module with a link cable.
6. Command module support clamp: To mount the command module to the powered or manual drum support stand or to the optional vehicle wall mounting kit.
7. Fuse holder: 5x20mm T3.15A 250V cartridge fuse.
8. RCA Video Jacks: Provide secondary input and output options for external composite video equipment.
9. Power Socket: DC power input from vehicle supply, battery box or mains adapter. For use with pushrod reels or as a standalone unit.
10. Compact Flash card slot: The command module uses a Compact Flash card to store video recordings, reports and pictures. Most stored files can be viewed or played on the command module or transferred to PC. Also used to store and upload software upgrades.
11. Keyboard Socket: Connects the keyboard.
12. Audio Socket: Connects the optional headset to record audio over videos.
13. USB-A socket: Reserved for future use.
14. USB-B socket. USB connection to transfer files to computers.

15. RJ-45 socket: Connects to a PC running compatible reporting software.
16. Optional Vehicle wall mount kit: to mount the command module to the side of your van (not shown).

### 2.1.1 Keypad

17. Function keys: Use to select menu items or activate shortcuts.
18. Camera key: Press to take screen captures.
19. Text key: Press to access the Text and Report menu.
20. Play: Enters the card browser menu. Starts video playback of selected file.
21. Pause: Press to pause video playback or recording.
22. Record: Press to begin a new video recording.
23. Stop: Press to stop video playback or recording.
24. Crawler stop: Stops the crawler moving.
25. Arrow keys: Use for navigation and to select system parameters.
26. OK: Press to select or confirm choices in the menu system.
27. LED Brightness/Camera Focus keys: Adjust LED brightness and camera focus. Fn + brightness key to adjust camera focus.
28. Rotate/Pan keys: Press to rotate the camera view. Fn + Rotate to pan left or right. Simultaneous press will re-center the view.
29. Zoom/Iris keys: Press to zoom in or out of the camera's subject. Fn + Zoom to modify the Iris. Simultaneous press will reset the zoom to unity, Fn + simultaneous press will reset to automatic iris.
30. Function key (Fn): Press and hold to activate different functions.

Figure 2.1: Command module

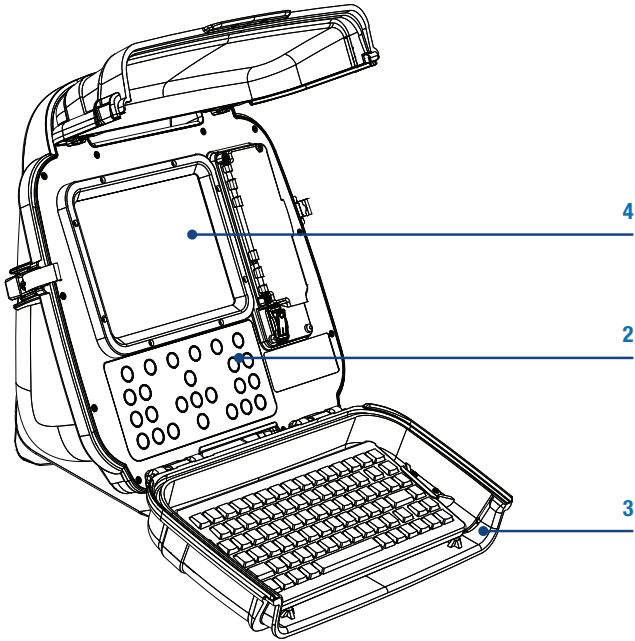

Figure 2.3: Command module I/O panel

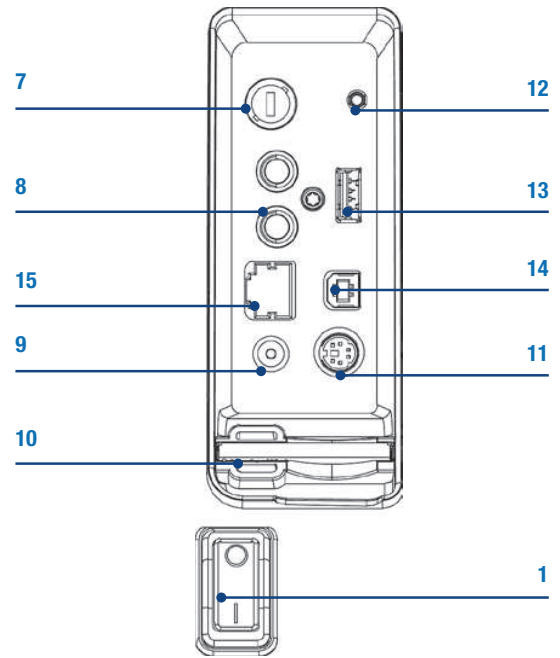

Figure 2.2: Command module rear view

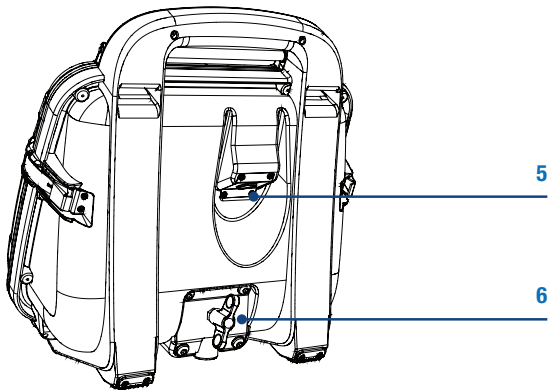
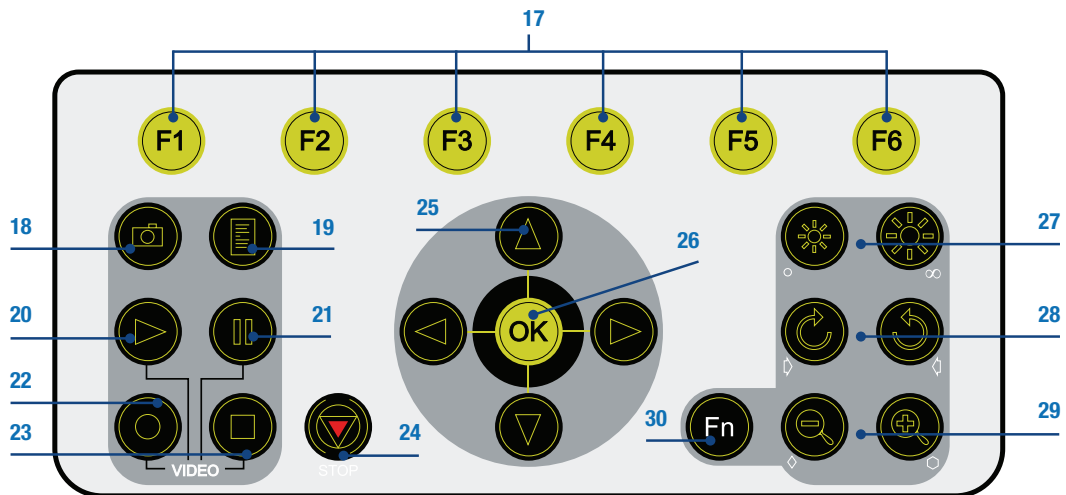

Figure 2.4: Command module keypad



## 2.2 Cable drums

The system supports either a powered or manual drum that can accommodate cable lengths of 100m (330'), 150m (495') or 250m (820'). The powered drum contains an integral power supply whilst the manual drum requires an external power supply unit.

The cable drum cassette in the powered drum is user-replaceable. Please refer to Appendix 9.5 for instructions on how to remove and install the cable drum cassette.

Optional lengths of cable are also available for both the powered and manual drums. Please refer to Appendix 9.5 for instructions on how to remove and install the cable.

Please visit [www.radiodetection.com](http://www.radiodetection.com) for a complete list of spares and accessories.

### 2.2.1 Powered drum

1. Command module support stand.
2. On/Off switch. Switches the system on or off.
3. Command module.
4. Reel compartment: Houses up to 250m (820') of cable wound onto the drum cassette.
5. Removable handle, handle bars and wheels: Allow you to manoeuvre the system easily into position.
6. Emergency stop: Instantly shuts off system power. When initiated, the system must be reset.
7. Pendant connector: For connecting the optional pendant controller.
8. Command module connector: To connect the command module link cable.
9. BNC Video Jacks: Provide secondary input and output options for external composite video equipment.
10. Power supply socket: To connect mains power.
11. Fuse holder: 5x20mm T12A 250V cartridge fuse.
12. Crank handle: Will allow the manual retrieval of the deployed cable. (Not shown).
13. Optional vehicle mounting rails: To secure the system in your van. (Not shown).
14. Cable rollers.

### 2.2.2 Manual drum

15. Cable drum: Houses up to 250m (820') of cable.
16. Cable brake.
17. Crawler connection terminal (Not shown).
18. Crank handle socket.
19. Command module support clamp.
20. PSU link cable socket.
21. Manual layering handle: To assist with laying cable evenly on the drum.
22. Cable rollers.

### 2.2.3 External PSU (manual system only)

2. On/Off switch. Switches the system on or off.
6. Emergency stop: Instantly shuts down the system power. When initiated, the system must be reset.
7. Pendant connector: To connect the optional pendant controller.
8. Command module connector: To connect the command module link cable.
9. BNC Video Jacks: Provide secondary input and output options for external composite video equipment.
10. Power supply socket: To connect mains power.
11. Fuse holder: 5x20mm T12A 250V cartridge fuse.
23. Link cable connection for manual drum.

### 2.2.4 Link cables

24. Command module link cable.
25. Manual drum link cable.

Figure 2.5: Powered drum with command module installed

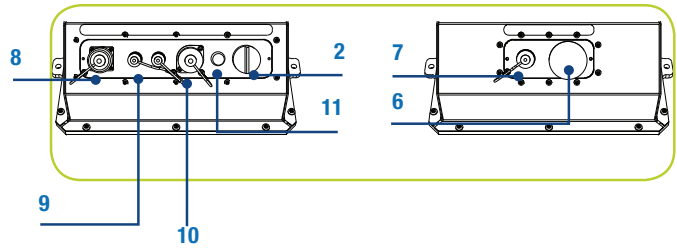
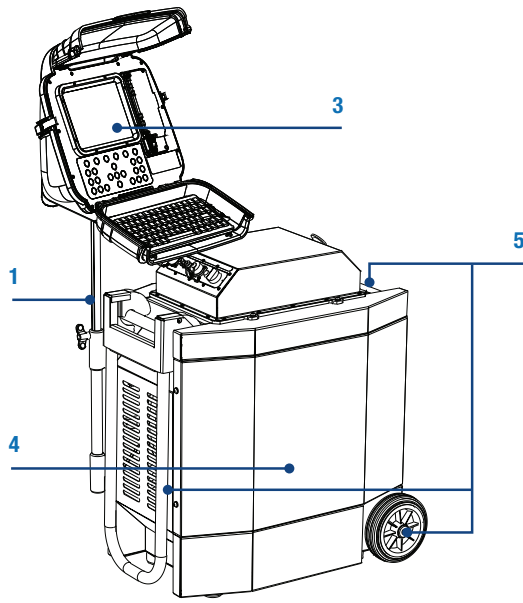

Figure 2.7: Front and rear connection panels (Common to powered drum and external PSU)

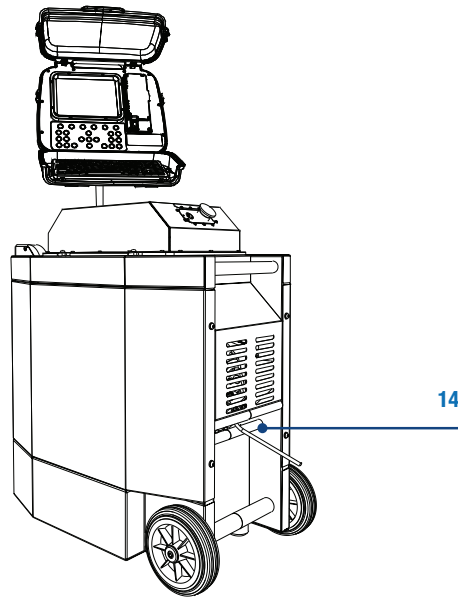

Figure 2.6: Manual drum

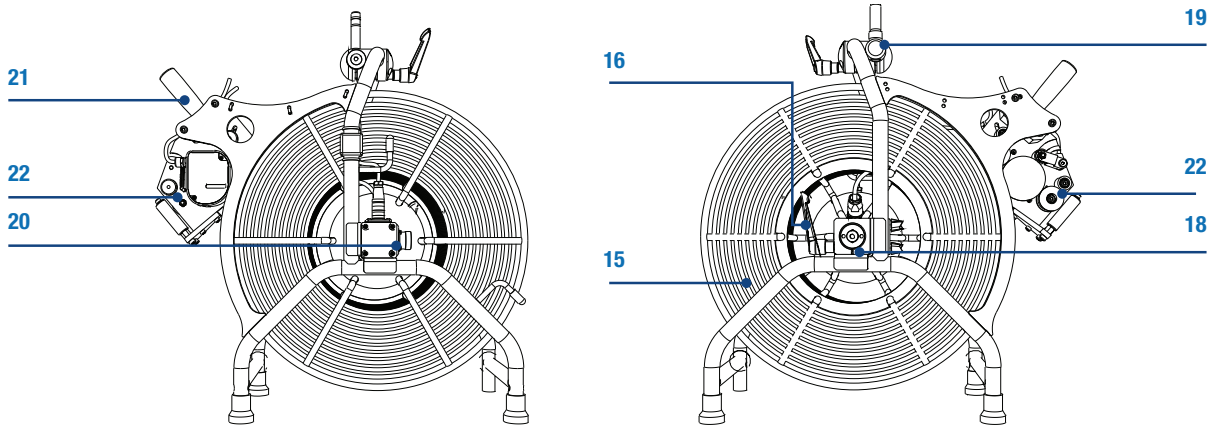

Figure 2.8: External PSU

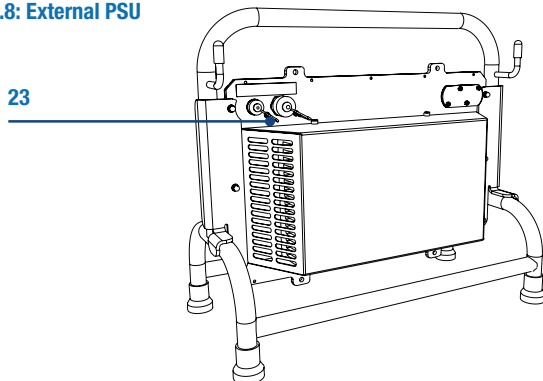
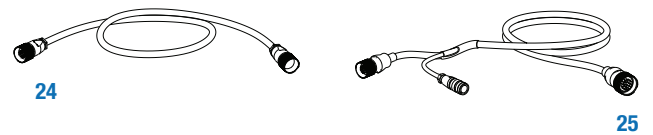

Figure 2.9: Link cables



## 2.3 Crawlers and Crawler cameras

The system offers two different crawlers: the P354 (100mm/4") and P356 (150mm/6"). Both crawlers are fully compatible with three interchangeable cameras. The P350-CAM-FW is a fixed, forward view camera. The P350-CAM-PT offers pan and tilt capabilities and the P350-CAM-PTZ offers pan, tilt and 10x optical zoom.

## 2.4 Pushrod reels and cameras

The command module is compatible with the full range of P330+ and P340 flexiprobe pushrod reels, cameras and accessories. When used with a pushrod system, the command module must be connected directly to the pushrod coiler. Power is supplied by mains or a vehicle adapter, which connects to the DC socket in the command module's I/O panel. When a pushrod system is connected, the command module's power switch will turn the system on and off.

Refer to 4.8.1 for information on how to configure the command module to drive a pushrod system

For information on assembling and using a pushrod system, refer to the P330+ and P340 flexiprobe user documentation available on the FlexiSight installation CD or at [www.radiodetection.com](http://www.radiodetection.com).

## 2.5 Accessories

The P350 flexitrax system features a range of accessories that expand its functionality and range of applications. Please visit [www.radiodetection.com](http://www.radiodetection.com), for a complete list of available accessories.

Figure 2.10: P354 crawler with P350-CAM-FW camera installed

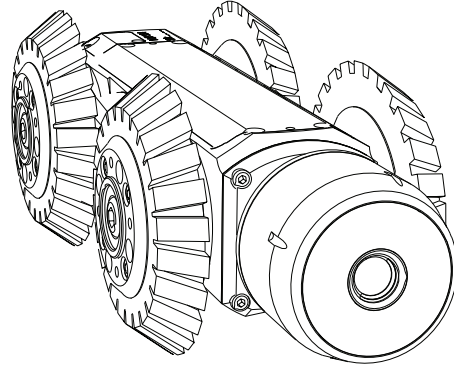
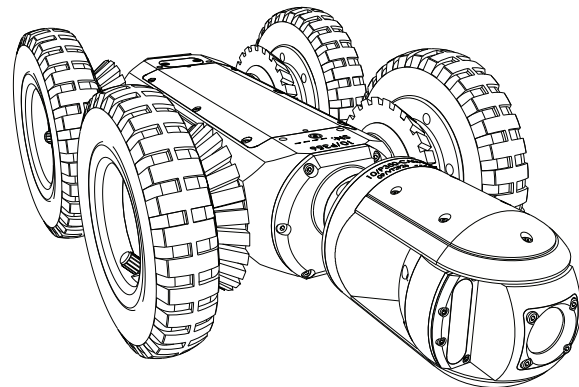

Figure 2.11: P356 crawler with P350-CAM-PTZ camera installed





# Section 3 – System assembly

The P350 flexitrac allows you to configure the system in a large number of ways, depending on the components you have chosen for your survey. This section provides details on assembling and setting up a system using either the powered or manual drum and external PSU.

**⚠ WARNING!** Before attempting to assemble the system, ensure that the powered drum or the manual PSU is switched off.

## 3.1 Crawler and accessories

You can configure the P354 and P356 crawlers with a variety of wheels, tires, cameras and accessories to suit a wide range of pipes and conduits.

Figure 3.1 demonstrates the modularity of the crawlers. It shows an exploded view of some of the many configurations available.

Figure 3.1: P356 crawler assembly

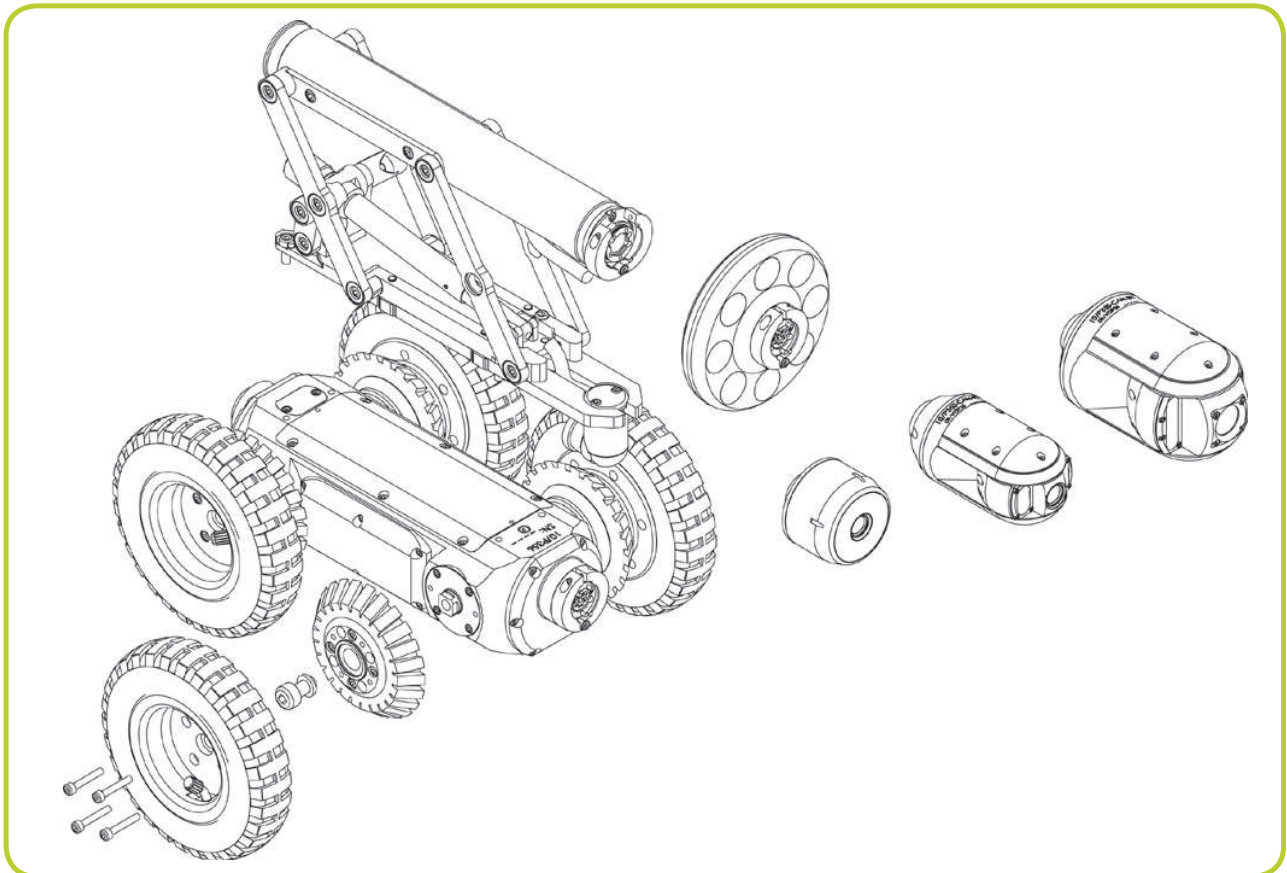

### 3.1.1 Crawler weight (P354 Only)

The crawler weight is a metal plate designed to increase traction on the P354 crawler by adding more weight to the crawler's body.

To fix this to the body, place the weight on the crawler's body before adding any other components or accessories and fix in place using the supplied screws.

### 3.1.2 Wheels and tires

The P354 is compatible with the 62mm (2.5") and 110mm (4.3") wheel sets, which can be connected in singular or twin configurations. This configuration allows you to deploy the P354 in pipes from 110mm (4") up to 380mm (15") in diameter.

The P356 is compatible with the 62mm (2.5"), 110mm (4.3") and 170mm (6.7") wheels, which can be connected in singular or tandem configurations. This configuration allows you to deploy the P356 in pipes from 150mm (6") to 610mm (24") in diameter.

The 62 and 110mm wheel sets are compatible with a hard or soft tire set to suit most traction requirements.

For a complete list of compatible wheels and tires, please visit [www.radiodetection.com](http://www.radiodetection.com).

Figure 3.3 (opposite) shows a range of recommended wheel and elevator configurations to suit a variety of pipe diameters and to position the chosen camera in the center of the pipe.

#### Connecting wheels and tires

Figure 3.2 demonstrates how to attach wheels and tires to the P354 and P356 crawlers (62mm and 110mm only).

The inner hub is located on the crawler's body. Place the wheel on the inner hub and secure in place using the outer hub clamp.

**NOTE: Make sure you affix the wheel screws firmly to the crawler body.**

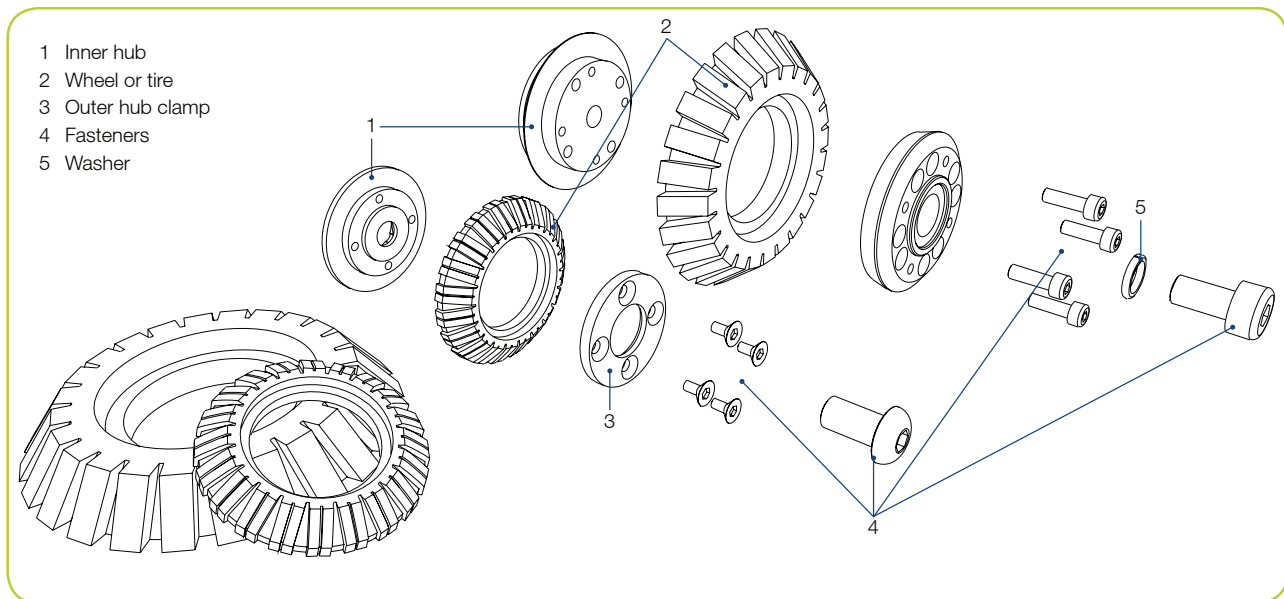
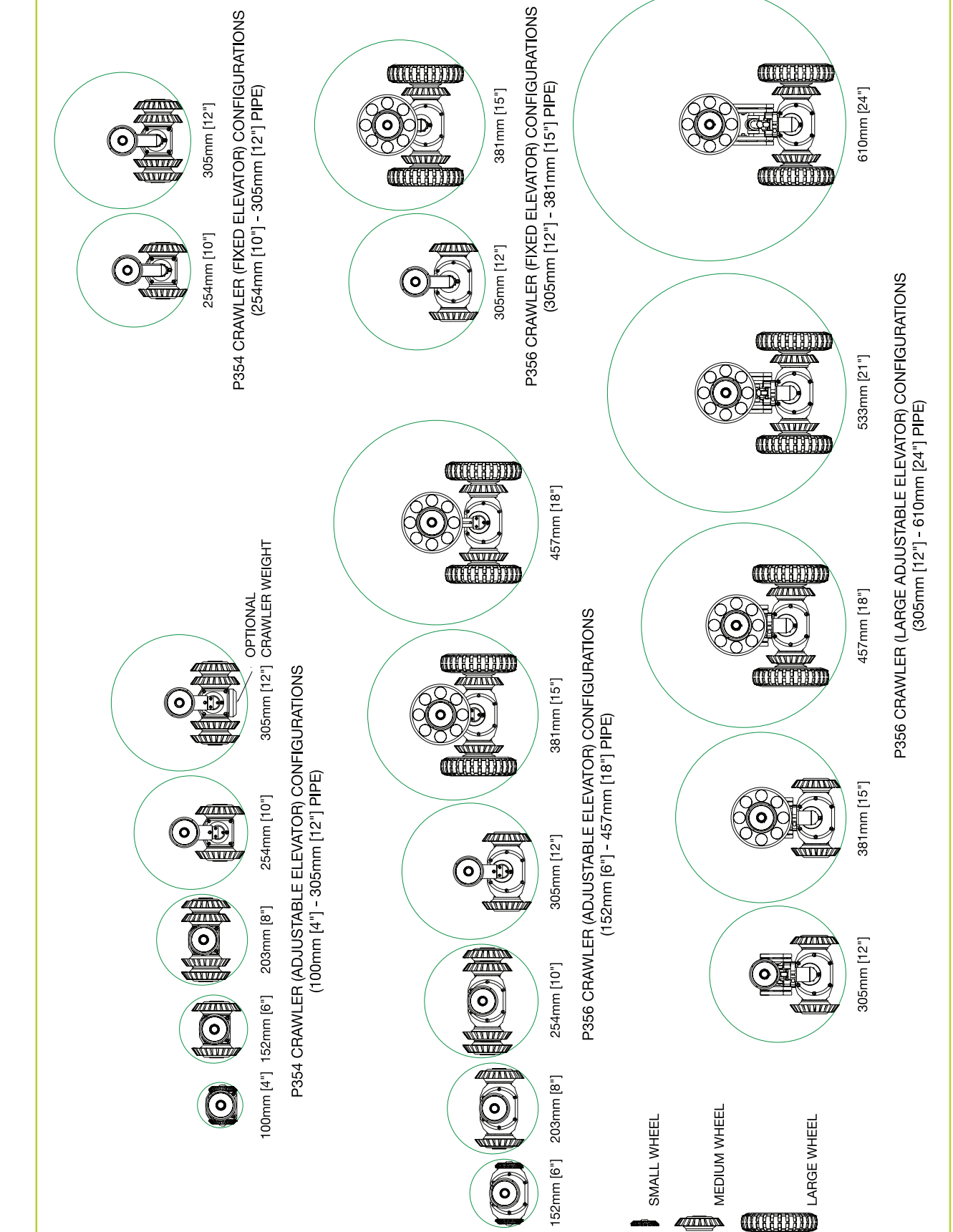
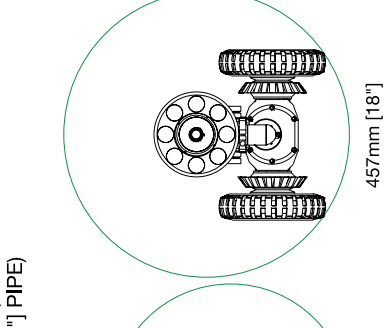
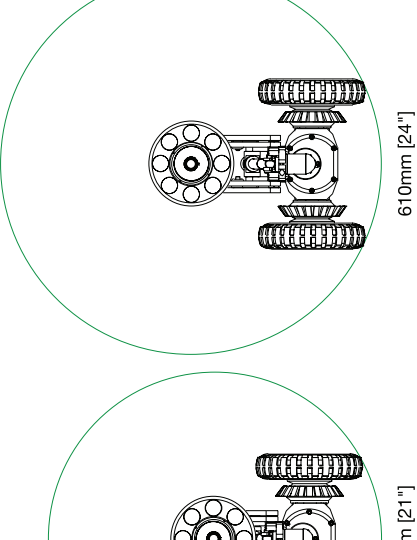
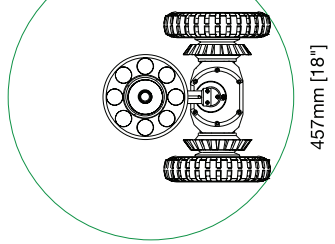
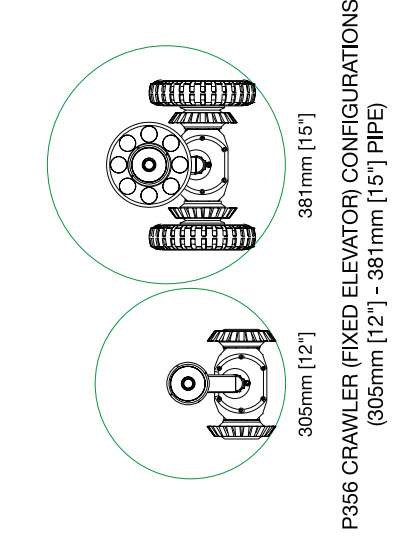
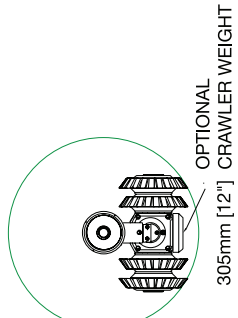
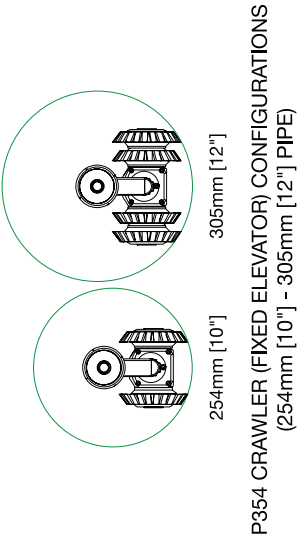

Figure 3.2: Connecting various tires

Figure 3.3: Crawler configurations (opposite)



### 3.1.3 Cameras

The P354 and P356 are compatible with three high-resolution cameras that support PAL or NTSC video standards.

All cameras offer remote focus capabilities and use the latest generation of ultra bright LEDs for optimum light performance.

Cameras can be fitted direct to the crawler's body or to an elevator or lighthouse if used. The cameras are simple to attach as they can only be fitted in one way. A single 3mm Allen-head screw is used to secure the camera's collar to the crawler's body, lighthouse or elevator.

#### Connecting cameras

Figure 3.4 illustrates the connection of cameras using the C-clamp connection. Note that the procedure is the same for all supported cameras.

Figure 3.4: Connecting a fixed view camera

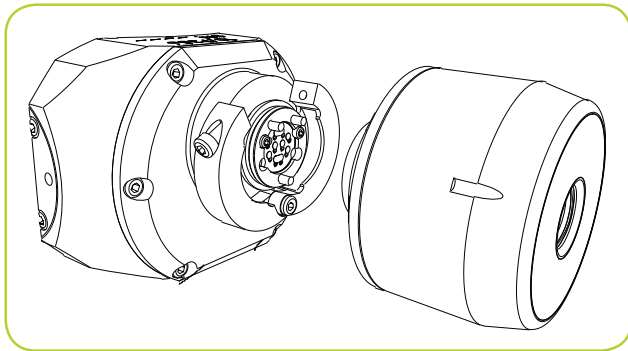

#### Supported cameras:

##### Fixed View camera

P350-CAM-FW (Figure 3.5): this robust and compact camera offers a focal range from 10mm to infinity and a 120 lm light source.

Figure 3.5: Fixed view camera

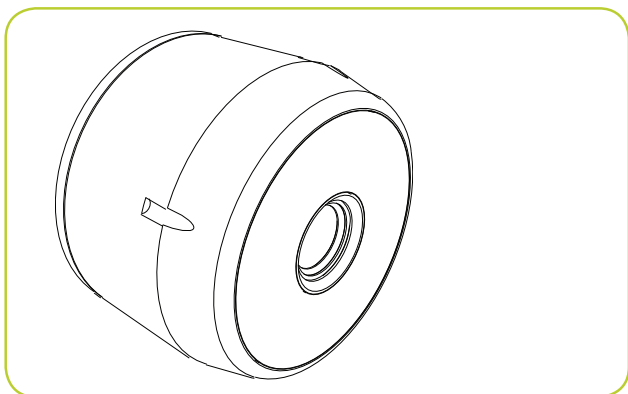

##### Pan and Tilt cameras

P350-CAM-PT (Figure 3.6): the pan and tilt capabilities provides the crawler with almost 360° vision. The pan and tilt camera's focal range is from 10mm to infinity; it features a 210 lm light source.

Figure 3.6: Pan and tilt camera

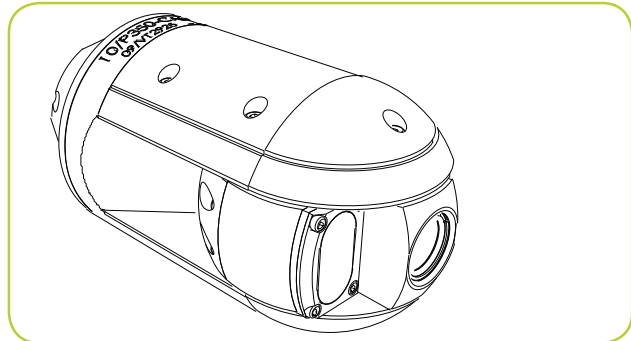

P350-CAM-PTZ (Figure 3.7): this camera has the same pan and tilt features as the P350-CAM-PT camera. The PTZ camera also features auto focus, 10x optical zoom with a focal range of 10mm (WIDE) to infinity and a 420 lm light source.

Figure 3.7: Pan, tilt and zoom camera

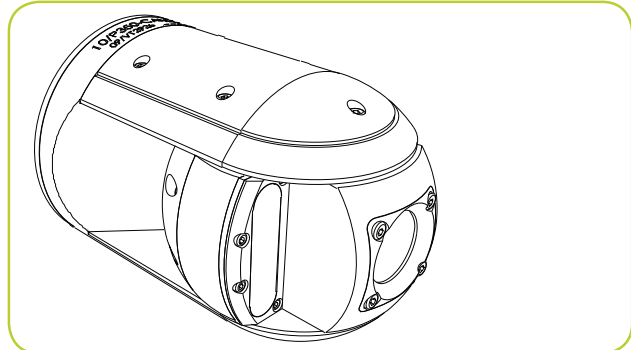

### 3.1.4 Elevator

The P350 elevators are used to elevate the camera and help center it in pipes 254mm (10") in diameter or larger, see Figure 3.3. The elevator is installed between the crawler and camera.

The P350 system offers a choice of 3 elevators:

- P350-ELV-F fixed elevator (Figure 3.8 left). The fixed elevator will deploy the P354 in pipes up to 300mm (12") and the P356 in pipes up to 380mm (15").
- P350-ELV-A adjustable elevator (Figure 3.8 center). The adjustable elevator will deploy the P354 in pipes up to 350mm (15") and the P356 in pipes up to 458mm (18").

- P350-ELV-LAM large adjustable elevator (P356 only) (Figure 3.8 right). The large adjustable elevator will deploy the P356 in pipes from up to 600mm (24").

**Figure 3.8: P350 camera elevators**

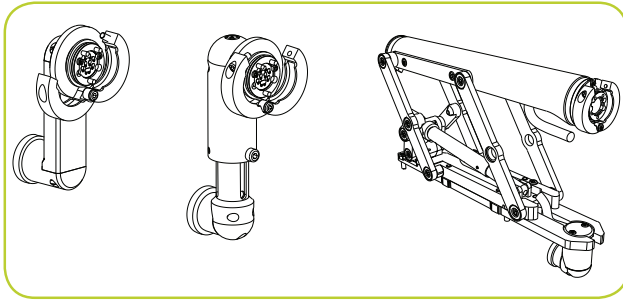

### Adjustable elevator

To adjust the P350-ELV-A elevator:

1. Loosen the Allen-head and the vent screws (Figure 3.9)
2. Set the camera mount to the desired height.
3. Tighten the Allen-head and the vent screws to secure the elevator.

**Figure 3.9: Adjustable elevator**

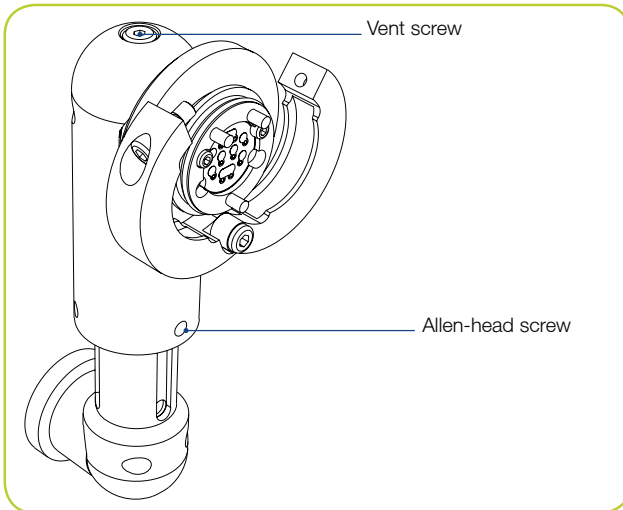

### Large adjustable elevator

To fit the large adjustable elevator to the P356 crawler align the four mounting holes and secure it using the four screws provided. This is demonstrated in Figure 3.10.

To adjust the P350-ELV-LAM elevator twist the square-recessed socket with the supplied chuck key to vary the height as required. This is demonstrated in Figure 3.11.

**Figure 3.10: Installing the large adjustable elevator**

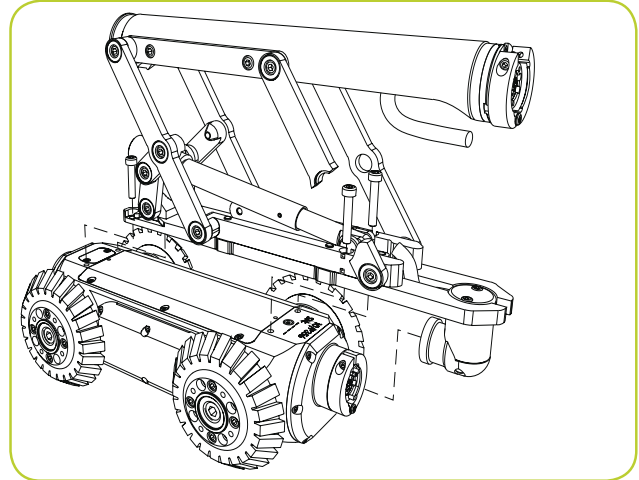

**Figure 3.11: Adjusting the large adjustable elevator**

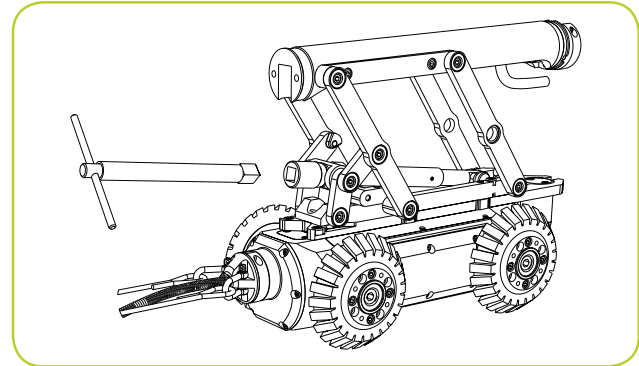

### 3.1.5 Auxiliary Lighthead

The lighthead accessory, see Figure 3.12, offers additional LEDs to provide the camera with more light when needed. With more light you can deploy the crawler in larger pipes or in pipes made from absorbent material that would otherwise reduce visibility when inspected with the standard camera LEDs.

The lighthead is fitted between the camera and the crawler or between the camera and the elevator. The lighthead provides up to an additional 850 lm.

**Figure 3.12: Auxiliary lighthead**

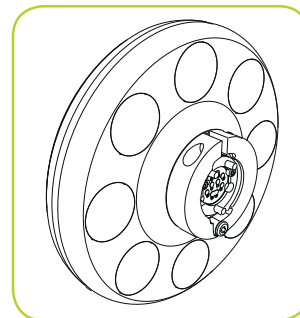

### 3.1.6 Crawler connection

Once you have fitted the crawler with the cameras, wheels and other accessories, you can connect it to the cable drum.

Connect the crawler cable termination to the terminal on the back of the crawler's body; use a 3mm Allen key to tighten the cable termination's C-clamp.

#### Cable strain relief and spring guard

The cable connecting the crawler to the drum features a strain relief assembly and a stainless steel spring guard. The spring guard helps to protect the cable end against damage to the cable sheath.

Figure 3.13 illustrates the strain relief clamp and spring guard.

Refer to appendix 9.8, Step 9, instructions 9 to 14 for a detailed guide on how to set up the strain relief and spring guard assembly.

Ensure that there is sufficient slack on the cable when the lanyards are taut.

Ensure the D-shackle retention pin's heads are pointing upwards.

**⚠ CAUTION: Never use the system without the strain relief properly assembled. Failure will damage the termination and may result in the crawler being disconnected from the cable**

Figure 3.13: Strain relief clamp and spring guard

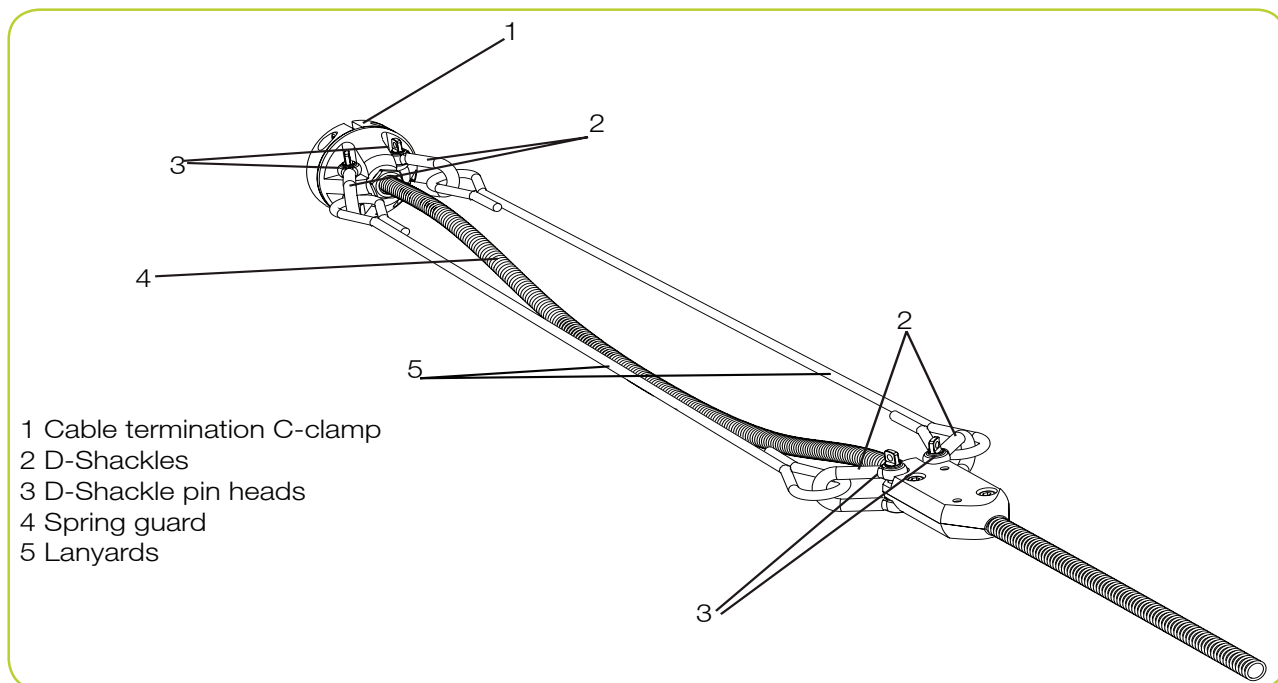

### 3.2 Crawler deployment tools

The crawler deployment grab tools for the P354 and P356 crawlers are optional accessories that allow an operator to safely deploy and retrieve a crawler into manholes, culverts and other access points. The grab tool can deploy and retrieve the crawler in conduits up to five meters (16.5 feet)\* deep. Using the crawler grab tool is highly recommended.

\*Using all four of the supplied guide rods. Maximum deployment depth is limited to the length of the Bowden cable.

**⚠ CAUTION! The rods are not designed to bear the weight of the crawlers and all attached accessories. Use durable rope (not supplied) to lower and retrieve the crawler. Choose high-quality rope that is certified to hold at least 50kg /110lb (for P354 crawlers) or 100kg/220lb (for P356 crawlers).**

Refer to Section 5.2 for a guide to crawler deployment and Section 5.8 for a guide to crawler retrieval using the deployment tools.

## 3.3 Manual drum and external PSU

The manual drum (Figure 2.6) is a light-weight system that can house up to 250m of cable. The external PSU (Figure 2.8) connects to the manual drum using the link cable (Item 25 in Figure 2.9). The single end connects to the manual drum and the split end terminals connect to the manual drum connection panel on the rear side of the PSU's handle.

**⚠ CAUTION! Do not connect the command module to the external PSU link cable connection terminals (item 23 in Figure 2.8) as this may damage the system.**

## 3.4 Powered drum

The powered drum (Figure 2.5) features a motorized cable reel compartment that can store up to 250 meters of cable. The cable is housed in a user-replaceable cassette. For information on changing this cassette, please refer to Appendix 9.5.

**NOTE: The drum is capable of retrieving deployed cable; however it is not designed to retrieve the crawler without the crawler's added assistance.**

## 3.5 Command module

### 3.5.1 Mounting

You can mount the command module to the powered drum using the support stand. The stand is fitted to the drum chassis and the command module fits on top. Once fitted to the drum, you can adjust the height of the command module to suit your preference of working environment.

If using a manual drum you can mount the command module to the support stand, which is clamped to the drum carrying handle.

### 3.5.2 Power, data and video

When using the manual or powered drum, a single link cable (Item 24 in Figure 2.9) supplies the command module with power, data and video. The link cable socket is located on the rear side of the command module (Item 5 in Figure 2.2).

Mount the command module and connect the controller cable to the controller terminal on the powered drum or external PSU (Item 8 in Figure 2.7).

### 3.5.3 Compact Flash card

Insert a high quality Compact Flash card into the card slot, which is located inside the Command Module's I/O panel (Item 10 in Figure 2.3).

Please note the orientation of the card before you attempt to insert it into the command module. Although a groove on the card will prevent you from inserting the card the wrong way this can be forced, which will damage the Compact Flash card receptacle.

For more information about Compact Flash cards, including selecting high quality cards, refer to Section 6.

### 3.5.4 Keyboard

The supplied keyboard is connected via the PS/2 connector in the I/O panel (Item 11 in Figure 2.3).

**NOTE: Only the supplied keyboard is compatible with the command module.**

### 3.5.5 Headset

The optional headset allows you to record and hear audio commentary in your video recordings. Connect the headset to the audio socket in the I/O panel (Item 12 in Figure 2.3).

## 3.6 External video equipment

You can connect a range of video equipment to the system using the video jacks on the command module (Item 8 in Figure 2.3), powered drum or the external PSU (Item 9 in Figure 2.7). This can include video recording and playback equipment or external monitors.

These devices are connected using standard composite video cable with RCA or BNC-type connectors as appropriate (not supplied).

**⚠ WARNING! Connected equipment must be earthed according to the equipment manufacturer's documentation. Failure to comply may result in electric shock and damage to the flexitrax system.**

# Section 4 – Command module and system setup

This section introduces the P350 command module and system setup.

## 4.1 Overview

The P350 command module acts as the main control unit and digital video processor for the flexitrax system. It is compatible with the powered drum, manual drum and external PSU and the full range of P330+ and P340 flexiprobe pushrod reels and cameras.

The 8" LCD displays the on-screen system menu, the camera's video feed or the selected video and picture files stored on the Compact Flash card. You can control the command module using the keypad or the keyboard; this manual will detail using both methods where applicable.

In addition to playback and control, the command module can be connected to external video equipment with the optional headset, to personal computers using the USB-B or the RJ45 sockets and to compatible *Bluetooth*® devices.

## 4.2 Powering up

When the system is correctly assembled, switch it on using the On/Off switch on the powered drum or external PSU.

**NOTE:** The command module takes approximately 10 seconds to display the first screen.

Depending on the settings, the command module will display one or two splash screens followed by the welcome screen (Section 4.4). The welcome screen displays important system information; note it and press OK to continue.

**⚠ CAUTION:** When you power off the system, wait at least 5 seconds before switching it on again. Failure to do so may cause the system to lock up.

**NOTE:** When the command module is switched ON with no camera connected, the screen will display a vertical color bar chart.

**NOTE:** If the Emergency Stop button is used at any time to shut down the system, the PSU must be reset by rotating the Emergency Stop button with the main switch set to OFF.

## 4.3 Getting help

The command module has a built in, context sensitive help screen. To access the help page, press Fn + F1 simultaneously on the keypad or Shift + F1 on the keyboard.

You can also view a list of keypad and keyboard shortcuts. Shortcuts allow direct access to main features and help to make operation of the system more efficient. To see a list of shortcuts press Fn + F2 simultaneously or press Shift + F2 on the keyboard.

A list of shortcuts is included in Appendix 9.1.

## 4.4 Welcome screen

The welcome screen is the first screen to appear after the Pearpoint logo and the optional splash screen. It provides important information about the status and settings of your system and should not be ignored. The welcome screen is illustrated in Figure 4.1.

Figure 4.1: Welcome Screen

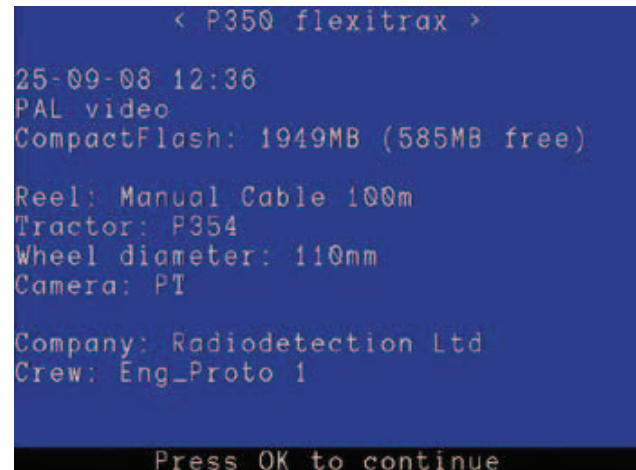

The welcome screen includes the following information:

- Video mode (PAL or NTSC depending on camera).
- Compact Flash card size and free space.
- Reel or drum type (see Section 4.8).
- Crawler Type: P354 or P356.
- Wheel Size (see Section 4.9.1).
- Camera Type: FW, PT or PTZ.



- Company as defined in the Company Details menu (see Section 4.10).
- Crew as defined in the Company Details menu (See section 4.10).

To clear the welcome screen, press OK on the keypad.

**NOTE :** The P350 Command Module, Drum and Crawler need to run compatible software versions, otherwise the system may not work correctly. If the software loaded on a component is incompatible with the rest of the system, this is reported as a “mismatch”. If a component does not have any software loaded as a result of a failed software upgrade this is reported as “no application”.

When a software "mismatch" or "no application" on a component is reported, you need to complete a software upgrade on that component to be able to use the system (refer to Section 9.3 for a instructions on how to obtain the latest software and how to perform a software upgrade).

## 4.5 On-screen display (OSD)

The OSD provides real time system and telemetry information overlaid on the video. The OSD also displays the system menu when it is active.

OSD content will change depending the menu and mode you are in as well as your personal settings.

The OSD displays the following information and graphics (see Figure 4.2):

- Mode: currently selected driving mode (see Section 5.3). This is not recorded on video.
- Status: crawler and drum communication status (see Section 5.3). This is not recorded on video.
- Time: system time (see Section 4.7).
- Date: system date (see Section 4.7).
- DVR: indicates recording (see section 5.4) and playback (see Section 6.6) status. Also indicates when a JPEG picture file is open (see Section 6.5). This is not recorded on video.
- Distance counter: crawler position from 0.0 in feet or meters (see Section 4.8).
- Page: the currently selected text page (see Section 7.3). This is not recorded on video.
- Numeric Inclinometer: displays the crawler's inclination in degrees or as a gradient percentage (see Section 4.9.2). (Drive menu only).
- Mimic: provides crawler driving and steering (P356 only) speed. Also provides pan and tilt controls when a pan and tilt camera is connected (see Section 5.3.3) (Drive menu only).
- System menu: main system menu (see Section 4.6). This not recorded on video.

**Figure 4.2 System onscreen display (OSD)**

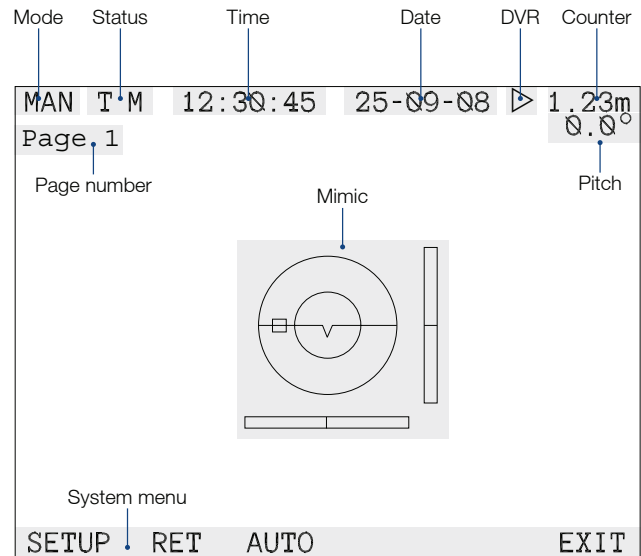

### 4.5.1 Customizing the OSD

You can customize many features of the OSD to suit your preferences. To modify the Drive OSD preferences refer to Section 5.3.2.

To modify non-Drive specific OSD information, go to SETUP -> OSD using the menu system (If you need help navigating the menu, refer to Section 4.6).

From the OSD menu you can adjust OSD layout and the appearance of text.

### 4.5.2 OSD layouts

The P350 System offers a choice of 3 different layouts for the position of Date, Time, Counter and Pitch; these layouts are: normal, TV and custom.

To choose a layout or to customize the position or visibility of the OSD information fields go to the Layout menu by pressing L'OUT.

Date, Time and Pitch can be individually hidden in all the layouts.

#### Choosing a layout:

1. Press P'SET to enter the OSD layout presets menu.
2. Use the Up and Down keys to select your desired layout.
3. Press OK to confirm your choice and return to the Layout menu.

## Normal layout:

This is the standard layout optimised to make use of the entire screen (See Figure 4.3). OSD information fields and overlaid text are positioned at the very edges of the display.

Figure 4.3: Normal OSD layout



## TV layout:

This layout is optimised for a DVD Recorder/TV screen (See Figure 4.4). OSD information fields and overlaid text are positioned in the graphic safe area of the display. Consult Section 8.7 for more details on producing TV compatible recordings.

Figure 4.4: TV OSD layout

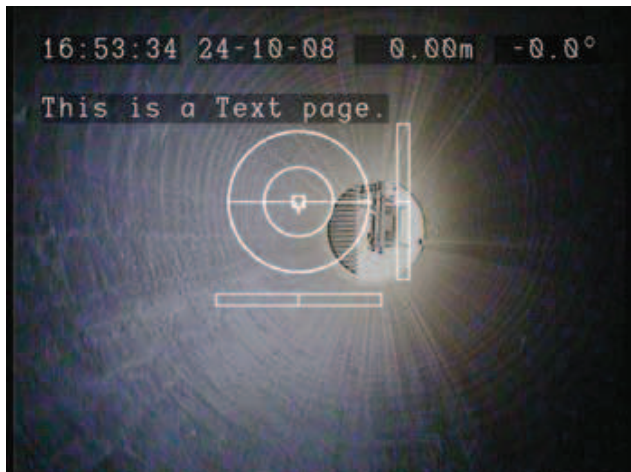

## Custom Layout:

This layout is customisable. The position of the 4 OSD information fields can be moved anywhere on the screen (See Figure 4.5).

Figure 4.5: Custom OSD layout

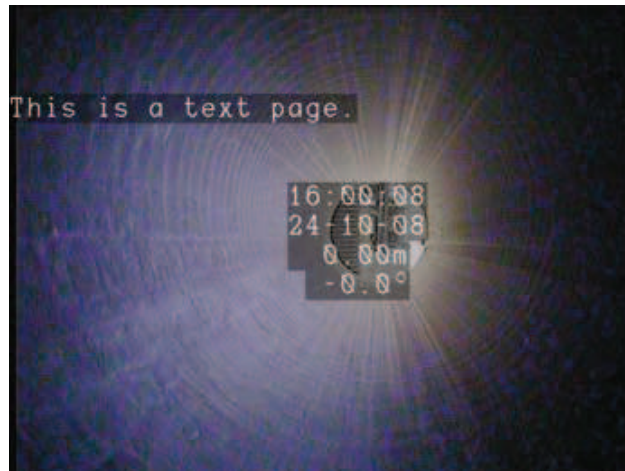

**⚠ CAUTION:** Be careful not to overlap the OSD fields as this will affect their readability on the screen and in recordings.

## Time and Date OSD:

You can hide or move these OSD fields around the screen (custom layout only):

1. Press TIME to enter the Time OSD menu or DATE to enter the Date OSD menu.
2. Use the arrow keys to position the OSD field (custom layout only).
3. Press RSTOR to restore the OSD field position to the normal layout.
4. Press On/Off to toggle the OSD field visibility.
5. Press OK to confirm your choice and to exit the menu.

## Counter OSD:

In custom layout you can also move the counter OSD field around the screen. You cannot hide this OSD.

1. Press COUNT to enter the counter OSD menu (custom layout only).
2. Use the arrow keys to position the OSD field.
3. Press RSTOR to restore the OSD field position to the normal layout.
4. Press OK to confirm your choice and to exit the menu.

## 4.5.3 System menu timeout

You can choose whether to have the system menu constantly visible on the screen or for it to disappear after 20 seconds.

1. Press MENU.
2. Use  $\triangle$  or  $\nabla$  keys to select the desired mode.

**Menu timeout on:**

If selected the system menu will disappear after 20 seconds. Press any function keys to make it visible again.

**Menu timeout off:**

If selected the system menu will be constantly visible on the screen. The system menu is not recorded.

3. Press OK to confirm your choice and to exit the menu.

### 4.5.4 Text appearance

You can customize the appearance of text on the OSD to suit your preferences.

#### Changing font color:

You can modify the text font color:

1. Press COLOR to enter the Color menu.
2. Use the  $\triangle$  or  $\nabla$  keys to select your desired color.
3. Press OK to confirm your choice and to exit the menu.

#### Changing OSD text transparency:

You can modify the transparency of the OSD field text background:

1. Press TRANS to enter the Color menu.
2. Use the  $\triangle$  or  $\nabla$  keys to select your desired transparency level from black to transparent.
3. Press OK to confirm your choice and to exit the menu.

#### Changing the background color for text pages:

You can modify the background color for system information pages and the Report, Card and file browser menus.

1. Press BACKG to enter the Background color menu.
2. Use the  $\triangle$  or  $\nabla$  keys to select your desired background color.
3. Press OK to confirm your choice and to exit the menu.

## 4.6 System Menu

The command module features an intuitive on-screen menu that appears on the bottom of the OSD. This menu provides users with access to all features and settings. The menu is organized in hierarchical layers.

Figure 4.6: Main screen showing top-level system menu



### 4.6.1 General navigation and text entry

Figure 4.6 illustrates the main page with the menu highlighted in black at the bottom of the screen. The figure shows the top-level menu. To navigate the menu, use the function and arrow keys on the keypad or keyboard. The  $\triangleleft$  key on the keypad will return you to the previous screen; press this key several times and you will return to the top-level menu. Once you reach the top-level menu, pressing the  $\triangleleft$  arrow will cause the menu to flash, indicating that you cannot go higher.

If the menu disappears from the screen – when on-screen timeout is enabled – then press any function key to return to the last viewed menu option.

Where a selection is required use the  $\triangle$  or  $\nabla$  arrow keys to cycle through the options in that menu screen. Use the OK key (or Enter on the keyboard) to confirm the selected choice.

**NOTE:** You can also use the keyboard's Function, ESC, Enter and cursor keys to navigate and select options in the menu.

Where required you can enter text by using the keyboard or keypad.

#### Entering text with the keyboard

The keyboard is fully featured; you can enter any available character and use navigation keys such as Home, End and the arrow keys to position the cursor.

1. To delete all text to the left of the cursor, select DEL  $\triangleleft$ .
2. To delete all text to the right of the cursor, select DEL  $\triangleright$ .
3. Press Esc to undo your changes and exit.
4. Press Enter to save your changes.

## Entering text with the keypad

You can enter text with the keypad arrows.

1. Use the  $\triangle$  or  $\nabla$  arrows to cycle through the list of available characters.
2. Use the  $\triangleleft$  and  $\triangleright$  arrows to move the cursor backwards and forwards along the line.
3. To toggle between upper and lower case press CAPS.
4. To delete all text to left of the cursor, select DEL  $\leftarrow$ .
5. To delete all text to the right of the cursor, select DEL  $\rightarrow$ .
6. Press CANCL to undo your changes and exit.
7. Press OK to save your changes.

## 4.6.2 SETUP menu

The SETUP menu provides access to all configuration settings on the command module and most connected components. Table 4.1 provides a comprehensive description of the SETUP menu.

**Table 4.1: Setup menu schema**

Menu			Description
DEVCE			Device menu.
	- CONTR		Command module menu.
		- TIME	Set the time.
		- DATE	Set the date.
		- KEYBD	Select keyboard type.
		- LANG	Select system language.
		- UPDTE	Update command module software.
		- MAIN	Update main controller software.
		- IFACE	Update interface software.
		- INFO	Display command module software version.
	- FONTS		Toggle between large and small fonts.
	- REEL		Drum and reel settings menu.
		- METR	Select metric measurements.
		- IMP	Select imperial (US) measurements.
		- RSIZE	Select current drum / reel type and cable / rod size.
		- DRUM	Drum and PSU menu.
		- ULOAD	Update powered drum and PSU software.
		- LOG	Creates a drum log file in the root directory of the CF card (service use only).
		- INFO	Display Drum or PSU software version.
	- TRACT		Crawler menu.
		- ULOAD	Upgrade crawler software.
		- LOG	Create a crawler log file in the root directory of the CF card (service use only).
		- INFO	Display crawler software version.
	- CAM		Camera menu.
		- W BAL	Adjust white balance.
		- NEXT	Next setting.

		-	PREV	Previous setting.
		-	RESET	Reset to automatic mode.
		-	PIPE	Optimize camera for pipe conditions.
		-	SURF	Optimize camera for surface conditions.
		-	ULOAD	Upgrade camera software.
		-	INFO	Display camera software version.
OSD				On Screen Display menu.
	-	L'OUT		On Screen Display Layout menu
		-	P'SET	Set OSD layout.
		-	Normal layout	Layout optimised for digital recording.
		-	TV layout	Layout optimised for analogue TV.
		-	Custom layout	Customisable layout.
		-	TIME	OSD Time Menu.
		-	RSTOR	Restore Time position to the default normal layout position.
		-	OnOff	Display or hide the time.
		-	DATE	OSD Date Menu.
		-	RSTOR	Restore Date position to the default normal layout position.
		-	OnOff	Display or hide the Date.
		-	COUNT	OSD Counter Menu.
		-	RSTOR	Restore counter position to the default normal layout position.
	-	MENU		Enable or disable menu timeout.
	-	COLOR		Select font color.
	-	TRANS		Select OSD transparency level.
	-	BACKG		Select background color.
COMMS				Communication menu.
	-	BT		Enter the Bluetooth menu
		-	SCAN	Search for nearby Bluetooth devices.
		-	PAIR	Pair with selected device.
		-	SEL	Select discovered device.
		-	SCAN	Search for nearby devices.
		-	KNOWN	Search for nearby Bluetooth paired devices.
		-	DEL	Deleted selected paired device.
		-	SEL	Select paired device.
		-	SCAN	Search for nearby devices.
	-	ETH		Enter the ethernet menu.
CMPNY				Company details menu.
	-	LOGO		Select a company logo (32KB maximum).
		-	SEL	Select logo picture from the root of the CF.
		-	SHOW	Show highlighted picture.

	–	REMOV		Remove current logo.
	–	COMPANY		Company name.
	–	CREW		Crew name.
	–	STREET		Company address.
	–	CITY		City.
	–	POSTCODE		Post or Zip code.
	–	PHONE		Telephone number.
	–	FAX		Fax number.
	–	EMAIL		Email.
RSTOR				Factory reset menu.
	–	YES		Restore all settings to their factory defaults.
	–	NO		Cancel system restore.

### 4.6.3 CARD menu

The card menu allows you configure Compact Flash card options; it also allows you to create, edit and delete inspection reports. Table 4.2 provides a detailed overview of the card menu.

**Table 4.2: CARD menu schema**

Menu		Description
DSTN		Destination folder menu.
	– NEW	Create new directory.
	– SET	Set the selected directory as the default destination.
	– RENAM	Rename the selected directory.
REPOR		Inspection reports menu.
	– NEW	Create a new report.
	– EDIT	Edit an existing report.
	– DEL	Delete a report.
CHECK		Compact Flash card status.
FMT		Format the Compact Flash card.
	– YES	Confirm format.
	– NO	Cancel format and return to the previous page.

### 4.6.4 DVR menu

The DVR menu allows you to adjust the command modules integrated digital video recorder settings. Table 4.3 provides a detailed overview of the DVR menu.

**Table 4.3: DVR menu schema**

<b>Menu</b>				<b>Description</b>	
INPUT				Input source menu.	
	-	Auto		Select the devices connected at startup giving preference to a P350 camera.	
	-	External		Select an external device.	
	-	Camera		Select a P350 camera.	
DESTN				Destination folder menu.	
	-	NEW		Create new directory.	
	-	SET		Set the selected directory as the default destination.	
	-	RENAM		Rename the selected directory.	
FNAME				Add a customized prefix to new recordings.	
TITLE				Video title menu.	
	-	Title on		Enable video title screen.	
	-	Title off		Disable video title screen.	
REPOR				Report popup menu.	
	-	Report popup on		Enable report popup menu.	
	-	Report popup off		Disable report popup menu.	
QUAL				Video quality menu.	
	-	HIGH		High quality preset.	
	-	MED		Medium quality preset.	
	-	LOW		Low quality preset.	
	-	ADV		Advanced quality settings.	
		-	SIZE	Set video resolution (screen size).	
			-	FULL	Select full video size (PAL or NTSE depending on camera).
			-	VGA	640 x 480 pixels.
			-	QVGA	320 x 240 pixels.
		-	BRATE	Set bitrate.	
			-	HIGH	Select highest bitrate.
			-	MEDIUM	Select medium bitrate.
			-	LOW	Select lowest bitrate.
		-	ENC	Set encoding quality.	
			-	Progressive Full	Encode video using full progressive scan.
			-	Progressive Half	Encode video using half progressive scan.
			-	Interlaced	Encode video using interlacing.
		-	FRATE	Set video framerate (FPS)	
			-	Maximum	Full NTSC (30FPS) or PAL (25FPS) framerate depending on camera.
			-	Medium	Select medium framerate (20FPS).
			-	Minimum	Select lowest framerate (10FPS).

## 4.6.5 SCRNM menu

The SCRNM menu allows you to set brightness and contrast of the command module's LCD. Table 4.4 provides a comprehensive description of the SCRNM menu.

**Table 4.4 Screen menu schema**

Menu	Description
BRI	Set brightness level.
CONTR	Set contrast level.

## 4.6.6 DRIVE

The DRIVE menu allows you to drive a crawler and set driving preferences. Table 4.5 provides a comprehensive description of the DRIVE menu.

**Table 4.5: Drive menu schema**

Menu			Description
SETUP			Drive settings menu.
	– DRUM		Drum menu.
		– METR	Select metric units.
		– IMP	Select imperial (US) units.
		– ASTOP	Set the Auto Stop point.
		– INFO	Display Drum or PSU software version and Auto Stop position.
	– TRACT		Crawler menu.
		– WHEEL	Set the current wheel size.
		– None	None selected.
		– 62mm	Small wheel set.
		– 110mm	Medium wheel set.
		– 170mm	Large pneumatic wheels (P356 only).
		– NPTCH	Zero the numeric inclinometer.
		– PPROF	Enable or disable the pitch profiler.
		– POWER	Control the power to the tractor and camera.
		– INFO	Display Crawler software version.
	– CAM		Camera menu.
		– W BAL	Adjust white balance.
		– NEXT	Next setting.
		– PREV	Previous setting.
		– RESET	Reset to automatic mode.
		– PIPE	Optimize camera for pipe conditions.
		– SURF	Optimize camera for surface conditions.
		– ULOAD	Upgrade camera software.
		– INFO	Display camera software version.
	– SONDE		Crawler sonde menu.
		– 512Hz	Select 512Hz transmission frequency.



		-	640Hz	Select 640Hz transmission frequency.
		-	8192Hz	Select 8192Hz transmission frequency.
		-	32768Hz	Select 32768Hz transmission frequency.
	-	OSD		OSD menu.
		-	MIMIC	Mimic menu.
		-	OnOff	Hide or display mimic.
		-	POSITION	Set mimic's position on screen.
		-	COLOR	Set mimic's color.
		-	NPTCH	Numeric inclinometer menu.
		-	RSTOR	Restore numeric inclinometer position to the default normal layout position.
		-	OnOff	Hide or display the inclinometer.
RET				Enter automatic retrieval mode.
	-	GO		Start retrieval
	-	CANCL		Cancel retrieval.
MAN /AUTO				Toggle between manual and automatic driving mode.
EXIT				Exit the DRIVE menu.

#### 4.6.7 TEXT and Report menu

The TEXT and Report menu allows you to create and edit reports and on-screen video text pages. The text menu is accessed by pressing . Table 4.6 provides a comprehensive description of the TEXT menu.

**Table 4.6: TEXT menu schema**

Menu		Description	
EDIT		Text menu.	
	-	CAPS	Toggles lower and upper case.
	-	DEL<	Delete all characters left of the cursor.
	-	DEL >	Delete all characters right of the cursor.
	-	CODES	Browse the Defect code file (if present).
	-	CANCEL	Returns to the TEXT menu without saving the changes.
REPOR		Displays the Report menu.	
	-	NEW	Create new report.
	-	EDIT	Edit existing report.
	-	DEL	Delete report.
HIDE		Hide the current onscreen text page (if any).	
COLOR		Chose font color.	
TRANS		Chose font transparency.	

## 4.7 Command module settings

Once the system is correctly assembled, you must configure it for the first time before you begin your pipe inspection. To set the command module's basic settings go to SETUP->DEVCE->CONTR and select from the following options:

- TIME: enter the correct time and press OK to accept or CANCL to cancel.
- DATE: enter the correct date and press OK to accept or CANCL to cancel. Select D-M-Y or M-D-Y to select your preferred date format.
- KEYBD: select the keyboard layout appropriate to your language and /or region.
- LANG: choose your preferred OSD language.
- FONTS: Toggle between large and small OSD fonts

**NOTE:** The system will store your preferences, cable length and wheels and preserve them when it is switched off.

## 4.8 Drum and reel settings

To access the drum and reel settings menu go to: SETUP->DEVCE->REEL and select from the following options.

- METR: Select metric units for the distance counter.
- IMP: Select imperial units for the distance counter.
- RSIZE: Select the correct drum or reel type and length.

### 4.8.1 Drum type and cable length

Setting the correct cable length is critical for maintaining communication between the command module and the crawler and to ensure a constant video quality. You must check this setting, and change it if required, every time you replace or change the cable reel or switch between pushrod and crawler-based configurations.

You can change the drum type and reel length using the RSIZE option in the REEL menu as described above. You can select the following options:

#### Manual or Powered drum

- Reel: Cable 100m (330').
- Reel: Cable 150m (500').
- Reel: Cable 200m (660').
- Reel: Cable 250m (820').

## Pushrod reels

- Reel: Rod P341 Plumbers 30m (100').
- Reel: Rod P341 Plumbers 60m (100').
- Reel: Rod P341 35m (120').
- Reel: Rod P342 60m (200').
- Reel: Rod P342 120m (400').
- Reel: Rod P343 150m (500').

**NOTE:** When selecting a Pushrod system the P350 Command Module will lock the DRIVE menu and prevent its access. ROD will be displayed in the OSD Status field.

## 4.9 Crawler and camera settings

### 4.9.1 Crawler wheel size

You must specify the size of the currently installed wheels as the system uses this information to calculate the crawler's speed.

**⚠ CAUTION! Incorrectly setting the wheel size may compromise the retrieval process and result in jamming the crawler's wheel on the cable.**

To set the wheel size, go to:

DRIVE->SETUP->TRACT->WHEEL using the menu system.

Use the  $\triangle$  and  $\nabla$  keys to select the correct wheel size:

- 62mm Small wheel set.
- 110mm Medium wheel set.
- 170mm Large Wheel set (P356 only).

Press OK to confirm your choice or  $\triangleleft$  to cancel.

### 4.9.2 Numeric inclinometer

The crawler features an integrated precision inclinometer that provides a real time numeric reading of the crawler's body inclination.

The P350 inclinometer supports two units of measurement: Degrees or Gradients. You should zero the inclinometer when the crawler is leveled prior to deployment.

To zero the inclinometer or setup the preferred units, go to DRIVE->SETUP->TRACT->NPITCH using the menu system.

- Press ZERO to zero the inclinometer.
- Press DEG to select Degrees.
- Press GRAD to select Gradients.

**NOTE:** The inclinometer is affected by a number of factors including tire wear and tear and pressure (pneumatic tires only).

### 4.9.3 Camera settings

The camera settings menu allows you to adjust the camera's white balance and operating mode. To change camera settings go to DRIVE->SETUP->CAM and select from the following options.

- W BAL: change the white balance or reset to factory settings. Press NEXT or PREV to change the default settings or RESET to go back to factory default.
- PIPE: optimize the camera for use in underground pipes.
- SURF: optimize the camera for use on the surface.

## 4.10 Company details

The P350 flexitrac allows you to customize your system by storing your company details and logo on the command module. These details are used to personalize reports and the video title screen.

**NOTE:** The video title screen is optional, for more information please refer to Section 4.11.2.

Once you save your company's information you will not need to enter it again unless you perform a factory reset (see Section 4.12).

Figure 4.7 Company information menu



### To set your company details:

1. Open the Company Information menu (SETUP -> CMPNY). See Figure 4.7.
2. To edit a field, use the  $\Delta$  and  $\nabla$  arrows to select the field you want to edit and then press OK.

### Logo

Your company logo. To enter it copy a JPEG version of your company logo (32KB maximum) into the root of a compact flash card and insert it in the command module.

**NOTE:** The root directory refers to the top-level directory of folder of the Compact Flash card. For more information about the Compact Flash card, please refer to Section 6.

1. Use the  $\Delta$  and  $\nabla$  keys to browse the root of the Compact Flash card.
2. Press SHOW to check the highlighted JPEG logo.

**NOTE:** The command module can only display pictures with width and height multiple of 16 pixels. Pictures of other sizes will not be displayed by the command module but will work in the final report.

3. Press SEL to select the desired logo file and OK to confirm.
4. Press REMOV to remove the current logo file.
5. Press  $\leftarrow$  to exit.

### Company

Use this field to store your company or trading name (30 char max).

### Crew

Use this field to record the name of the crew or individual who is in charge of the P350 flexitrac (30 char max).

### Street

Use this field to record your company's street address (50 char max).

### City

Use this field to record your company's city or town (20 char max).

### PostCode

Use this field to record your company's post or zip code (10 char max).

### Telephone

Use this field to record your company's contact telephone number (20 char max).

## Fax

Use this field to record your company's fax number (20 char max).

## Email

Use this field to record your company's contact email address (30 char max).

## 4.11 Splash and video title screens

The P350 flexitrax features several splash and information screens.

### 4.11.1 Splash screens

The P350 flexitrax command module displays two splash screens at start up. The first is the Pearpoint splash screen. This screen is fixed and will appear during start up.

The second splash screen is optional and you can use your own graphic, such as a logo. This screen will appear after the Pearpoint logo and before the welcome screen (Section 4.4).

### Creating a splash screen

Your company may already have a logo or other image suitable for use as a splash screen. If not then you can create your own splash screen in an image editor such as Adobe Photoshop or Microsoft Paint.

**NOTE:** Your image must in JPEG format with horizontal and vertical dimension in multiples of 16 pixels and size not larger than 768 by 576 pixels.

Save your image as "splash.jpg" and copy the file to root folder of the Compact Flash card. For more information on copying files from your computer to the Compact Flash card please refer to Section 6.7.

### 4.11.2 Video title screen

You can insert a short title screen at the beginning of your recordings. The title page, if enabled, will add a few frames containing information to the start of a video recording. The title page is illustrated in Figure 4.8. To enable or disable the video title screen go to DVR->TITLE.

Figure 4.8: Video title page



1. Select Title ON or Title OFF by using the  $\Delta$  or  $\nabla$  keys.
2. Press OK to confirm your choice.

The title page includes the following information:

- Company name.
- Crew name.
- Date and Time.
- Reel or drum type.

The company and crew name are taken from your company details stored in the P350 flexitrax. See Section 4.10 for more information.

## 4.12 Ethernet configuration

You can connect the P350 command module to a PC running a compatible reporting software to control OSD and text position as well as retrieving telemetry data.

Ensure that you have the latest software installed. See section 9.3 for more details.

Please note that the boot-up time for the command module will be longer if no ethernet connection is present.

To connect to a PC you may use a standard or a crossed patch RJ45 leads connected to the RJ45 receptacle in the command module I/O panel (fig 2.2 item 15).

Use the standard RJ45 straight lead if you are connecting through a network hub or a router.

Use the crossed patch lead if you are connecting to a PC directly.

To configure the ethernet port, go to SETUP -> COMMS -> ETH. See Figure 4.9.

**Figure 4.9: Ethernet configuration**

```
< Ethernet Configuration >
Status           <Active>
> Boot type     <Static IP>
IP address       10.44.22.100
Subnet mask      255.0.0.0
Address gateway  10.44.10.128
```

Status indicates if the P350 system is connected or not.

Use the  $\triangle$  and  $\nabla$  arrows to select a setting and press OK to edit it.

Boot Type: Choose between DHCP and Static IP.

If you choose Static IP you have to configure the following three parameters:

- IP address: enter a valid IP address
- Subnet mask: enter a valid Subnet Mask
- Address gateway: enter a valid Address gateway.  
You will need to switch the system OFF then ON to make the settings active.

## 4.13 Restoring factory settings

You can restore the command module to its factory settings. Restoring the command module will erase all your system settings, personal preferences and your company details.

To reset the command module to factory default:

1. Go to SETUP and select RSTOR.
2. Select YES to continue or NO to cancel and return to the previous screen.

# Section 5 – System operation

This section introduces the procedure for deploying the P350 flexitrac system and inspecting pipes and conduits.

## 5.1 Emergency stop

The Emergency Stop button located on the PSU (Item 6 in Figure 2.7) will completely shut down the command module and all system components when pressed. As a fail-safe, the system must be reset before you can switch on the system again. Do not reset the system until it is safe to do so. To reset the system ensure the power is switched off at the main switch (Item 2 in Figure 2.7), rotate the Emergency Stop button clockwise and then switch the power back on.

**NOTE:** Initiating an Emergency Stop may result in loss of data on the Compact Flash card, particularly if a recording or playback was in progress.

## 5.2 Deployment

Once the system is correctly installed, you can deploy the crawler in the pipe or conduit you wish to survey. Care must be taken when deploying the crawler, particularly if it is being deployed into deep conduits and cisterns via manholes with limited access.

**WARNING:** The crawlers are heavy! Observe proper lifting procedures when handling, deploying and retrieving the crawler.

**Never lower crawlers or other heavy equipment into manholes while personnel are working in the manhole.**

**⚠ CAUTION!** Do not attempt to lift the crawler by the cable. Do not drop the crawler as it may damage the camera and the system's electronics.

### 5.2.1 Before deployment

Assess your deployment and safety requirements before you begin. Different environments may pose risks and challenges that you may be unaccustomed to.

Check that no hazardous gases are present. The P350 flexitrac is not suitable for use in potentially explosive environments.

The crawlers are heavy and may be difficult for one person to lift and guide into position.

Seek assistance if required and always use correct heavy-lifting practices.

Pearpoint recommend the use of downhole (Figure 5.1) and manhole rollers as there is a risk of scoring or damaging cables during deployment and during a survey. For more information see Section 5.2.3.

Figure 5.1: Downhole cable rollers

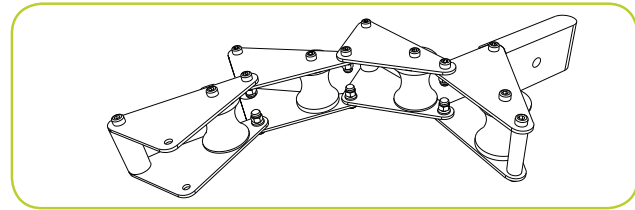

### 5.2.2 Using the crawler deployment tool

The crawler deployment tool has the following components (Figure 5.2):

- Toggle clamp
- Crawler grab
- Bowden cable
- 4 interconnecting rods

Figure 5.2: Crawler grab kit

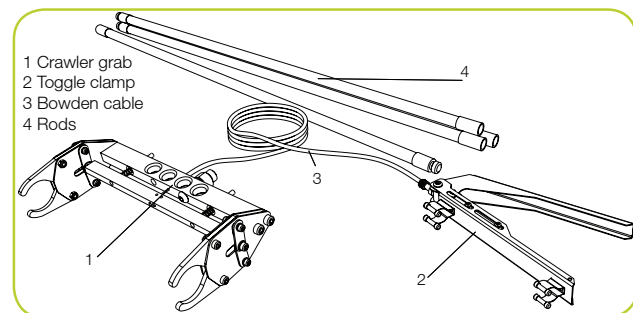

Before you attempt to assemble and use the crawler grab tool, ensure that all parts are included in the kit.

**⚠ CAUTION!** The rods are not designed to bear the weight of the crawlers and all attached accessories. Use durable rope (not supplied) to lower and retrieve the crawler. Choose high-quality rope that is certified to hold at least 50kg /110lb (for P354 crawlers) or 100kg/220lb (for P356 crawlers).

Figure 5.3: Crawler grab setup

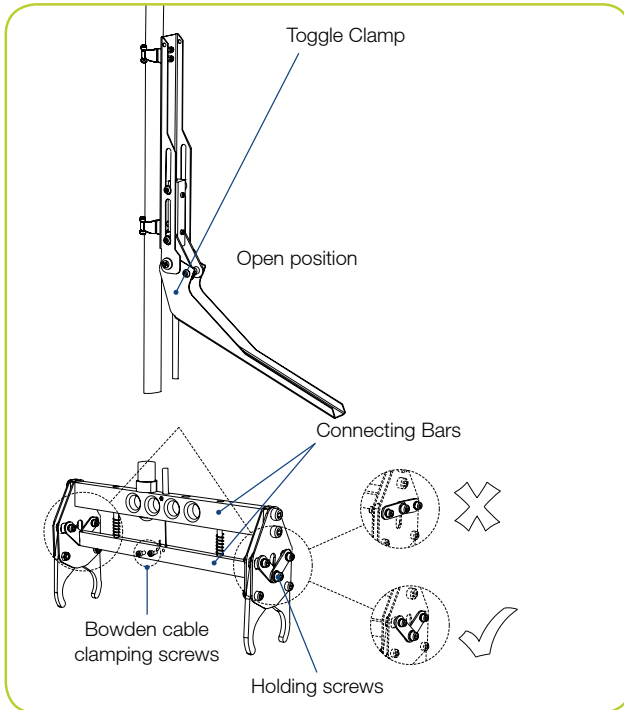
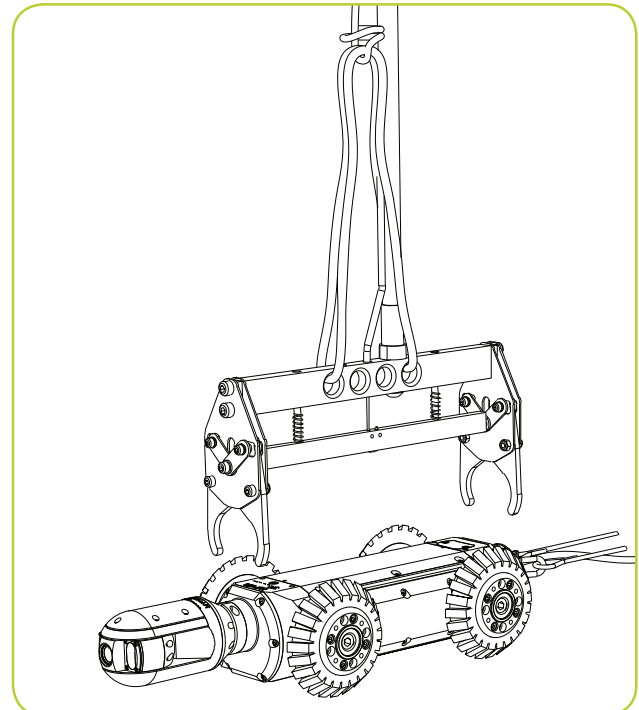

Figure 5.4: Crawler grab and crawler



## Testing and Adjustments

1. Without assembling the positioning rods, place the toggle clamp away from the crawler grab as far as the bowden cable allows, ensuring a straight run from the toggle clamp to the crawler grab.
2. Fully open the toggle clamp. Ensure the lower connecting bar's holding screws, at both ends, are in the lowest position as per figure 5.3. If they are proceed to point 6.
3. If an adjustment is required, slacken the 2-off cable clamping screws (see figure 5.3).
4. Force open the two connecting bars as far as possible and pull taut the cable using suitable tool (i.e. pliers).
5. Fully tighten the cable clamping screws to secure the now taut bowden cable in place.
6. Test adjusted deployment tool by opening/closing toggle clamp and noting responding action on crawler grab.

## Installation and deployment

**⚠ CAUTION!** Failure to follow this procedure may result in severe damage to the crawler and camera system.

1. Assemble as many rods as are required by screwing them together.
2. Attach the rods to the crawler grab.
3. Attach a sufficient length of durable rope to the crawler grab.
4. Attach the toggle clamp to the top section of the rods.
5. Position the grab over the crawler (see Figure 5.4) and close the toggle clamp to lock the crawler in place.
6. If you are using the large adjustable elevator (see Figure 5.5), lock the crawler grab to the elevator.
7. Check that the crawler is clamped securely. Ensure the lower connecting bar's holding screws, at both ends, are in the upmost position as per figure 5.6.
8. Use the grab rope to lower the crawler into manhole. If required, adjust the toggle clamp's position to ensure it remains above ground.

**NOTE:** The crawler may spin as it descends; use the rod to guide and steady the crawler.

Figure 5.5: Crawler grab and crawler with attached elevator

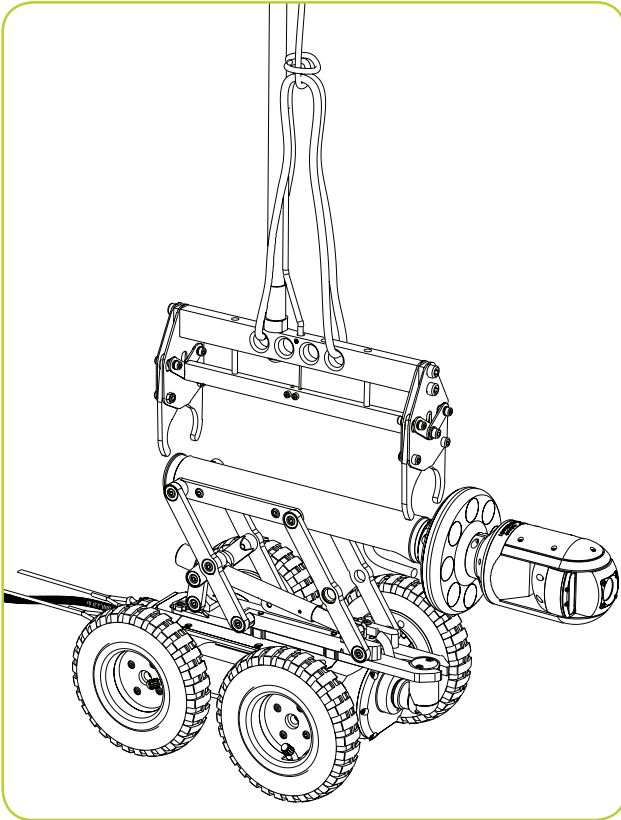

Figure 5.6: Crawler grab in the closed position

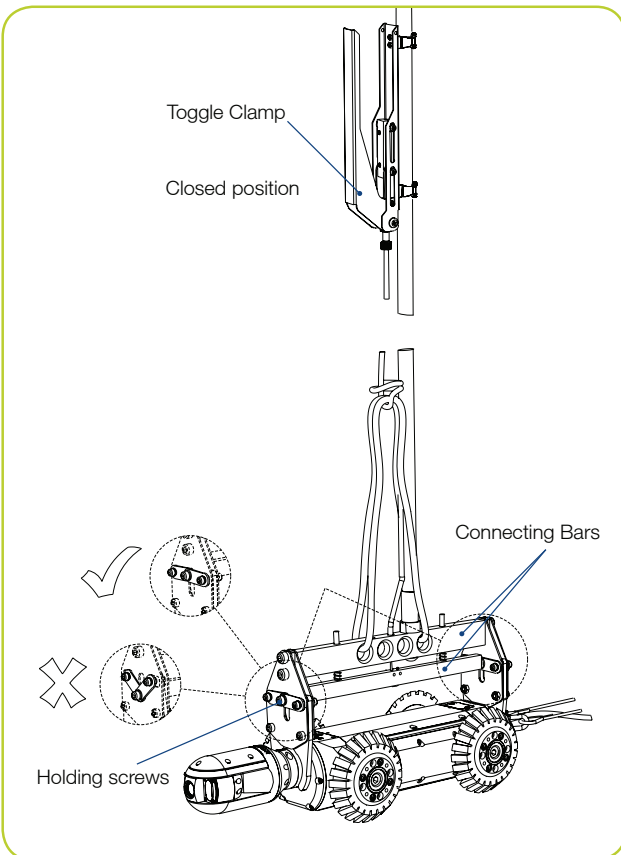

Figure 5.7: Lowering the crawler into a manhole



9. When the crawler reaches the bottom of the manhole, use a combination of the rope and rods to position the crawler in the desired orientation.
10. When the crawler is positioned to your satisfaction, release the toggle clamp's lever to disengage the crawler.
11. Pull the crawler grab up to the surface.

### 5.2.3 Cable and manhole rollers

The optional cable deployment rollers (Figure 5.1 on page 28 and Figure 5.8 below) help protect the cable from scoring on concrete and other abrasive materials. Pearpoint recommends that you always use cable deployment and retrieval rollers.

Figure 5.8 demonstrates the use of a manhole roller and the protective downhole tiger-tail rollers. Note the position of the tiger-tail roller below the surface.

Figure 5.8: Using cable rollers

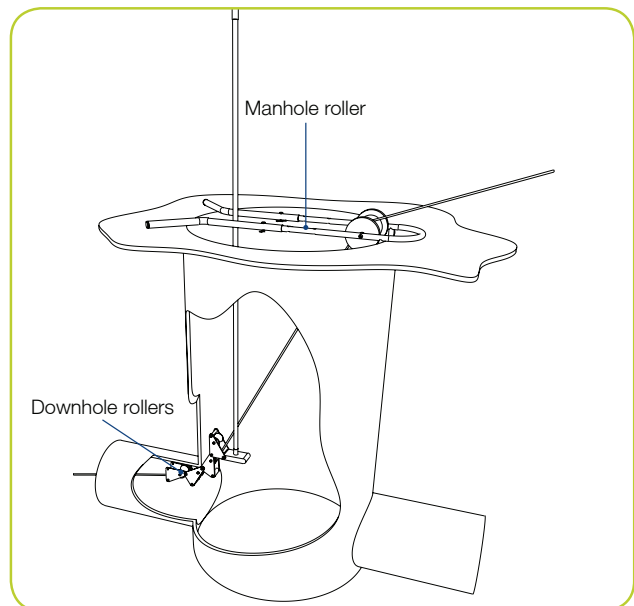



## 5.2.4 Distance counter and Auto Stop point

Once you have deployed and positioned the crawler in the manhole, using manhole rollers to protect the cable and ensuring that the cable protection spring has cleared the drum rollers (Item 14 in Figures 2.5 and Item 22 in Figure 2.6), you should zero the distance counter.

The zero (0.0) position is used to decide when to stop the system when reversing or retrieving the crawler. This is a safety feature.

You can reset the counter to zero at any time during operation by pressing the  $\triangle$  and  $\nabla$  keys simultaneously or by pressing F10.

You can also set a different stop point called Auto Stop. The system will stop reversing when this stop point is reached.

To set this limit: move the crawler to desired counter position, go to DRIVE->SETUP->DRUM and press ASTOP.

Please note that the Auto Stop position is saved by the system and it will be active until is reset.

To reset the Auto Stop point: zero the counter and set this to become the new Auto Stop limit.

To review the currently set Auto Stop limit go to DRIVE->SETUP->DRUM and press INFO.

You can also enter a new distance (up to  $\pm 327$ m).

1. Press F9.
2. Enter the distance and press OK to confirm.

**NOTE: Resetting or varying the distance counter during a survey will render the automatic retrieval function ineffective as the crawler will return to the new zero position and not the point where the crawler began the survey.**

When in custom layout you can move the OSD counter field around the screen to suit your preferences. See section 4.5 for more information.

## 5.2.5 Sonde

The P354 and P356 crawlers feature an integrated, multi-frequency sonde. The sonde allows you to locate the crawler's position using a Radiodetection cable and pipe locator such as an RD7000DL.

You can choose the desired transmitting frequency in the Sonde settings menu which you will find by going to SETUP->SONDE from the main DRIVE menu.

1. Press POWER to activate or deactivate the sonde.
2. Use the  $\triangle$  and  $\nabla$  keys to select the desired transmitting frequency between: 521Hz, 640Hz, 8192Hz and 32768Hz.

3. Press OK to confirm the selection and exit to the previous menu.

You can also use the shortcut Fn + F5 to activate or deactivate the sonde without having to enter the Sonde menu

For more information on locating the sonde, please refer to the documentation that came with your cable and pipe locator.

## 5.3 Driving crawlers

This section provides detailed instructions for driving and retrieving the P350 crawlers when used with the manual or powered drum. Although the principle is the same, the powered drum offers several automated features that make it easy to retrieve the crawler automatically.

**NOTE: Make sure you have set the correct wheel size before you attempt to drive the crawler.**

Pearpoint recommends that you practice driving the crawler on the surface in a safe environment before attempting to deploy the crawler underground for the first time. In addition to practising driving techniques, it provides a good opportunity to understand how the system operates.

### 5.3.1 System stop

You can stop the drive system, including the crawler and the powered drum at any time by pressing the spacebar, Ctrl + C or .

**NOTE: When using the keyboard the spacebar will only work in drive mode. Press Ctrl +C or  to stop the crawler under all circumstances.**

When stopped the crawler will be in Brake mode. Press the spacebar, Ctrl+C or  to toggle the Brake.

**! CAUTION! System stop is not a substitute for making an Emergency Stop. If there is any emergency use the Emergency Stop button located on the PSU. Please refer to Section 5.1 for more information.**

### 5.3.2 Drive mode and OSD

To drive a crawler, you must be in drive mode. You can access drive mode by selecting the DRIVE option from the main menu.

**NOTE: If you have selected a Pushrod, the DRIVE menu will be locked and ROD will be displayed by the OSD.**

**NOTE: The P350 Command Module, Drum and Crawler need to run compatible software versions, otherwise the system may not work correctly.**

When accessing the drive mode the system will automatically check the components' software for compatibility and or problems.

If a valid application is missing on any of the components as a result of a failed upload, a warning message will be displayed recommending a software upgrade. Subsequently a “no application” warning will be shown.

If the software loaded on a component is incompatible with the rest of the system a warning message will be displayed recommending a software upgrade.

When a software “mismatch” or a “no application” on a component is reported, you need to complete a software upgrade on that component to be able to use the system (refer to Section 9.3 for a instructions on how to obtain the latest software and how to perform a software upgrade).

In the DRIVE menu, the command module’s onscreen display (OSD) (Figure 5.9) will provide you with critical information, navigation and telemetry assistance as well as pan and tilt camera controls (if available) using the mimic display.

The driving OSD includes the following information:

- Mode.
- Status.
- Time.
- Date.
- DVR status.
- Distance counter.
- Page.
- Numeric inclinometer.
- Mimic.

Some information displayed on this screen can be hidden or moved. See Section 4.5 for more information.

Figure 5.9: Driving mode OSD

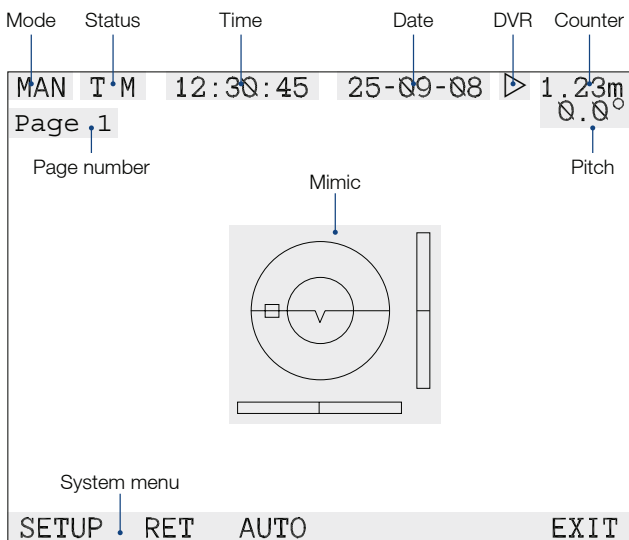

## Driving Mode

The mode indicator displays the current drive mode. The indicated modes are:

- AUT: automatic mode.
- MAN: manual mode.
- RET: retrieval mode.

**NOTE:** If the system is set to interface to a push rod then the DRIVE menu will not be accessible and ROD will be displayed in the MODE field of the OSD. See Section 4.8.

## Communication status

The communication status (COMMS) provides important information about connected devices and the integrity of the connection signal. The following information is indicated:

- T: crawler present.
- B: crawler present and braked.
- P: powered drum connected.
- M: manual drum connected.

When the T or B and P or M icons are colored green it means the devices are correctly connected and the communication link is good. If the T or P change to red then it means that either the crawler (T) or the powered drum (P) has stalled or is about to stall.

If the T, P or M characters are not displayed then the crawler, powered drum or external power supply are not connected correctly or may be malfunctioning.

## System time and date

The system time and date are displayed on the top of the OSD (Normal layout). The appearance of the time and date is controlled using the OSD menu in the main SETUP menu. Refer to Section 4.5 for more information on changing the look, visibility or position of the date and time OSD fields.

## DVR status

This icon displays the current digital video recorder (DVR) status. It indicates when a video is playing, recording, when recording or playback is paused or if the video is fast-forwarding or rewinding. It also indicates when a JPEG picture is viewed on screen.

**NOTE:** This field is not recorded.

## Distance counter

The distance counter indicates the crawler’s distance from the 0.0 position in feet or meters, depending on how you configured the command module (see Section 4.8).

To reset the counter, please refer to Section 5.2.4.

## Numeric inclinometer

The tilt or inclinometer reading displays the crawler’s inclination (or pitch) in degrees or gradients (percentage).

To change the inclinometer settings go to:

SETUP->TRACT->NPTCH from the main DRIVE menu.

You can reset the inclinometer at any time to zero; however Pearpoint recommends that you zero the inclinometer prior to deployment and when the crawler is level. Do not zero the inclinometer unless the crawler is completely level, otherwise the inclinometer readings will be incorrect.

To reset the inclinometer:

1. Press ZERO. The command module will prompt you to check that the crawler is level.
2. Press OK to reset the inclinometer or press
3. CANCL to return the previous menu.

To set the inclinometer to degrees or a percentage:

1. Press DEG to display degrees or GRAD to display the inclination as a percentage.

When in layout custom mode (see Section 4.5.2) you can move the inclinometer OSD field around the screen or hide it to suit your preferences.

You can change the OSD inclinometer settings in the NPTCH OSD Menu, which you will find by going to SETUP->OSD->NPTCH from the main DRIVE menu.

Press OnOff to display or hide the inclinometer OSD field.  
or

1. Select POS and use the arrow keys to select the position of the inclinometer on the screen.
2. Press OK to confirm your choice and return to the previous screen

or

3. Press RSTOR to restore the position to the default position on the normal layout.

### 5.3.3 Mimic

Mimic is an intuitive on-screen feature that helps you control the movements of the crawler and the position of the camera's viewing angle (PT and PTZ cameras only). Mimic will only appear in driving mode (if enabled) and is dependent on the type of camera you are using.

#### Basic mimic

The basic mimic display (Figure 5.10) appears by default or when a P354 crawler is connected to the system. Basic mimic features an artificial horizon and a speed indicator that shows the crawler's forward and reverse speed. The artificial horizon (center line) indicates the crawler's inclination as it traverses the pipe. The horizon will rotate clockwise or anticlockwise relative to the crawler's roll and move up or down relative to the crawler's pitch; note that pitch is also represented by the numeric inclinometer.

Figure 5.10: Basic mimic

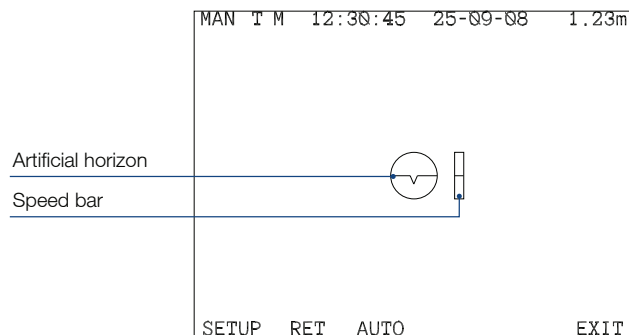

#### Steering mimic

Steering mimic (Figure 5.11) is displayed when a P356 crawler is connected to the system. In addition to the features of the basic mimic, steering mimic features a steering bar that indicates when the crawler is turning, steering left or right and the speed at which it is moving.

Figure 5.11: Steering mimic

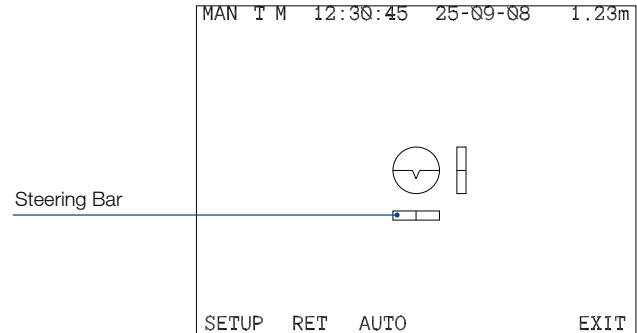

#### Pan and tilt camera mimic

Pan and tilt camera mimic (Figure 5.12) is displayed when a pan and tilt camera is connected to the system. Pan and tilt camera mimic provides a two dimensional representation of a pan and tilt camera's three dimensional range of movements. The mimic cursor, represented by the square box, acts as a target, which can be positioned using the following keys on the keyboard:

- W (up).
- A (left).
- S (go to).
- D (right).
- X (down).

Once you have positioned the cursor on the desired position, press the S key and the camera will automatically move itself to look at the target.

See 5.3.4 for more information on how to use the pan and tilt mimic display.

Figure 5.12: Pan and tilt mimic with steering bar

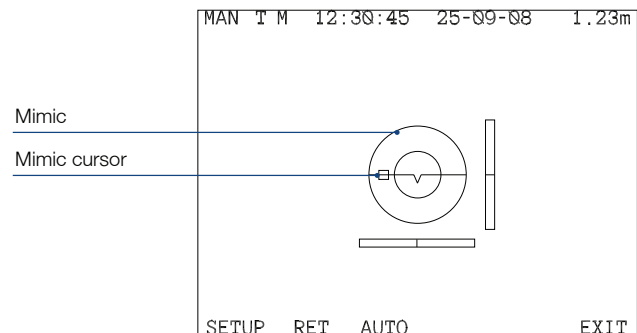

## A note on automatic camera movements

When you use mimic to control the camera's viewpoint, the camera uses a series of calculations to determine its current position and the new target. To do so it may manoeuvre in an unexpected way. This is normal, please be patient while the camera orients itself.

## Customizing mimic

You can change the appearance of mimic to suit your preferences. From the DRIVE menu go to: SETUP->OSD->MIMIC and choose from the following options:

- OnOFF: toggle mimic display on or off.
- POSITION: adjust the position of the mimic display on screen.
  1. Use the arrow keys to move the mimic display around the screen.
  2. Press OK to confirm your choice and to exit to the previous menu.
- COLOR: change mimic's color.
  1. Use the  $\triangle$  and  $\nabla$  arrows to choose the desired mimic color.
  2. Press OK to confirm your choice and to exit to the previous menu.

## 5.3.4 Navigating with advanced mimic

The inner circle represents the camera's ability to move up to 90° directly up, down, left or right. The inner circle allows you to point the camera in every direction in front of the crawler. The upper semi-circular area represents the area in front of and above the crawler. The lower semi-circular area represents the area in front of and below the crawler.

For example, if you press the A key until the cursor moves to the 9 o'clock position on the inner circle and press the

S key the camera will swivel 90° to the left (Figure 5.13.4). Likewise if you move the cursor to the 12 o'clock position on the inner circle and press S the crawler will look 90° up (Figure 5.13.6).

The outer circle represents the camera's remaining field of vision between 90° and approximately 300° in any direction. The upper semi-circular area represents the area above and behind the crawler. The lower semi-circular area represents the area below and behind the crawler.

For example, if you move the target cursor to the 12 o'clock position, half way between the inner and outer circles, the camera will look directly above and behind by 135° (Figure 5.13.9).

See table 5.1 and fig 5.13 for more examples.

The best way to learn mimic is to practice moving the camera while you can see the crawler. Start by moving the cursor to the cardinal points of the both the inner and outer circles and observe the camera's behaviour when it moves. Once you have mastered the basics, try different points on each circle and then start experimenting in targeting the areas between the circle lines.

## 5.3.5 Pitch profiler

When in drive mode you can activate the Pitch Profiler. When this is activated the command module will create a pitch log file that records distance against the crawler's pitch or inclination. The log file is saved in the current working directory and can be later reviewed by using the file browser (see section 6.3) or by using a PC. See section 6.3.2 for information on the file name format.

From the DRIVE menu go to: SETUP->TRACT and press PPROF to activate or to disable the Pitch Profiler and to open or close the log file.

You can also press P on the keyboard to toggle the Pitch Profiler directly from the DRIVE menu.

**NOTE: Do not remove the CF card before disabling the Pitch Profiler as this may corrupt its content.**

Table 5.1: Advanced mimic controls

Figure 5.13	Pan (Horizontal)	Rotate (Vertical)	Result
1	45°	0°	Camera Pans 45° Left
2	45°	45°	Camera Pans 45° Left & Rotates 45°
3	45°	90°	Camera Pans 45° Left & Rotates 90°
4	90°	0°	Camera Pans 90° Left
5	90°	45°	Camera Pans 90° Left & Rotates 45°
6	90°	90°	Camera Pans 90° Left & Rotates 90°
7	135°	0°	Camera Pans 135° Left
8	135°	45°	Camera Pans 135° Left & Rotates 45°
9	135°	90°	Camera Pans 135° Left & Rotates 90°

Figure 5.13: Advanced mimic controls

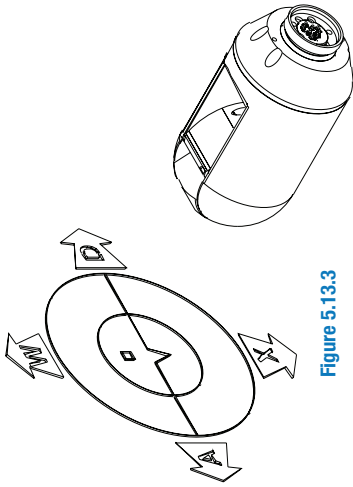

Figure 5.13.1

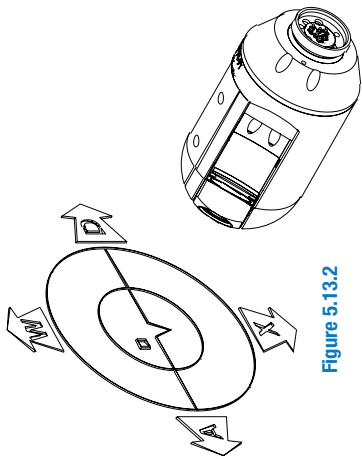

Figure 5.13.2

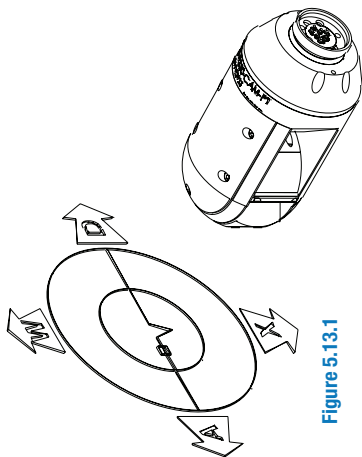

Figure 5.13.3

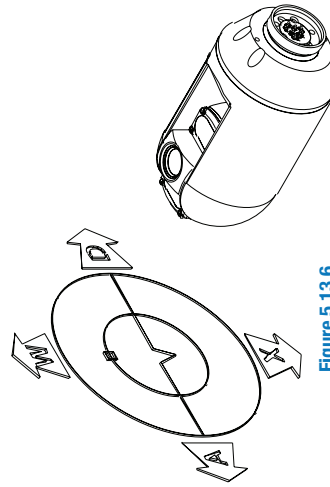

Figure 5.13.4

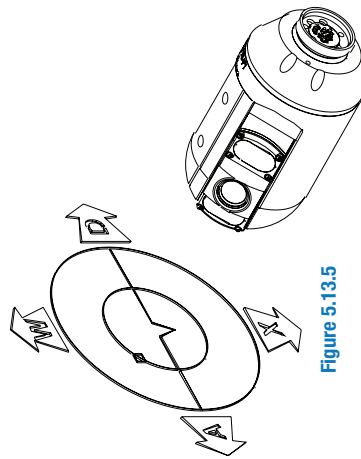

Figure 5.13.5

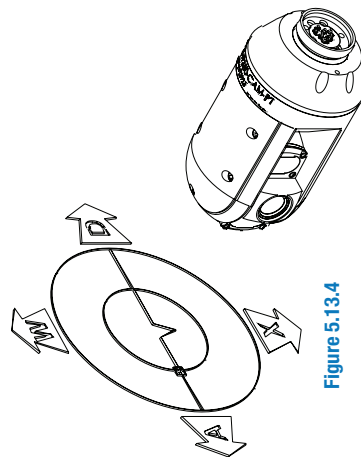

Figure 5.13.6

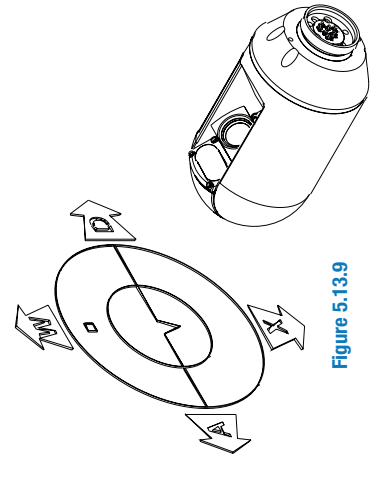

Figure 5.13.7

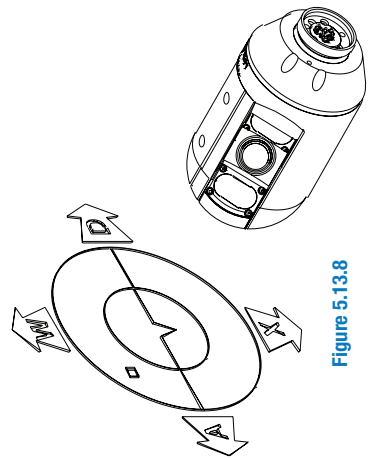

Figure 5.13.8

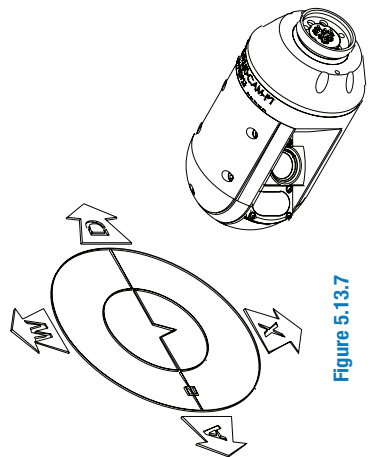

Figure 5.13.9

## 5.3.6 Manual system

**NOTE:** The P354 and P356 crawlers feature an automatic roll-over drive correction system: if they roll-over for any reason the direction of movement will remain the same.

### Moving forward

**NOTE:** There is no difference in operation between the Manual or Automatic mode when moving the crawler forwards.

To move the crawler forward, press  $\triangle$ .

Pressing the  $\triangle$  arrow subsequent times will increase the crawler's forward speed incrementally. A sustained press of the  $\triangle$  key will accelerate the crawler until it reaches its maximum speed or until you release the key.

To slow the crawler, press  $\nabla$ . Subsequent or sustained presses will decelerate the crawler faster until it comes to a stop.

**NOTE:** If you continue to press  $\nabla$  when the crawler has stopped, it will move in reverse. The crawler will automatically stop when the cable counter reaches 0.0 or the Auto Stop point (if set).

### Reversing

**⚠ CAUTION!** When reversing or retrieving the crawler ensure that the cable is retrieved at the same or higher speed than the crawler. Failure to do so may cause the crawler to get tangled in the cable and stall.

Use the crank handle to retrieve the cable. Use the manual wind layering handle to ensure the cable is laid evenly in the drum.

You can reverse the crawler in Manual (MAN) or Automatic (AUT). Press F3 to toggle between Automatic and Manual driving modes.

### Manual mode

In Manual mode, the crawler will start moving backwards as soon as it is driven.

**NOTE:** A message will flash on your screen warning of a cable hazard. This message will not be recorded to video.

Press  $\nabla$  to reverse the crawler. Increase the speed by holding or pressing  $\nabla$ . Decrease the speed by holding or pressing  $\triangle$ .

Ensure that you retrieve the cable at the same or higher speed than the crawler as this may cause the crawler to get entangled in the cable and stall.

Use the crank handle to aid the operation.

## Automatic mode

In AUT mode the crawler will not move backwards until it detects that the cable is being retrieved. Automatic mode is recommended for most situations.

To enable the crawler ensure to be in Automatic mode and press  $\nabla$  once.

**NOTE:** The mimic speed bar is disabled in automatic mode. The crawler's speed is automatically set to match the retrieval speed of the cable.

The crawler will stop moving if the cable is no longer retrieved.

## 5.3.7 Powered drum

**NOTE:** The P354 and P356 crawlers feature an automatic roll-over drive correction system: if they roll-over for any reason the direction of movement will remain the same.

### Moving forward

You can move the crawler forwards as soon as you enter the DRIVE menu. To move the crawler forward, press  $\triangle$ .

Pressing  $\triangle$  subsequent times will increase the crawler's forward speed incrementally. A sustained press of the  $\triangle$  key will accelerate the crawler until it reaches its maximum speed or until you release the key.

To slow the crawler, press  $\nabla$ . Subsequent or sustained presses will decelerate the crawler faster until it comes to a stop.

**NOTE:** If you continue to press  $\nabla$  when the crawler has stopped, it will move in reverse.

### Reversing

**NOTE:** The crawler will automatically stop when the cable counter reaches 0.0. However, the crawler's momentum may cause it to roll a short distance beyond the 0.0 position. Please allow for this when you deploy the camera and zero the distance counter.

The powered drum supports two driving modes: automatic and manual. The main difference is that when reversing in manual mode, the crawler and powered drum operate independently. Manual driving gives you more control over the crawler and drum but can increase the risk of jamming the crawler wheels on the cable, particularly if the crawler reverses over the cable. Press F3 to toggle between Auto and Manual driving modes.

As with forward movement, you must be in the DRIVE menu to reverse the crawler. From a stationary position, press  $\nabla$  to reverse the crawler.

Pressing ▾ subsequent times will increase the crawler reverse speed incrementally.

Decrease the speed by holding or pressing △. If you continue to press △ when the crawler has slowed to a standstill, the crawler will start moving forwards.

In automatic mode, the powered drum will automatically retrieve the cable as the crawler reverses. To avoid the risk of jamming the wheels in the cable, the crawler will reverse at a slower speed than the cable.

In manual mode however, the drum will not retrieve the cable and you must synchronize the speed of the crawler and the cable. To rewind the cable in manual mode, hold the Fn key and press ▾ on the keypad. Hold this key combination to accelerate the rewind speed.

Decrease the speed by holding or pressing Fn + △.

As already mentioned in section 5.2.4 the system will stop reversing when the Auto Stop limit and the zero point have been reached.

**⚠ CAUTION! In manual mode, make sure the cable is retrieved faster than the crawler speed. This will help to avoid the risk of jamming the cable in the crawler wheels.**

### Automatic retrieval

The powered drum features an automatic retrieval function. This function is designed to retrieve the crawler at a constant, optimal speed. This speed cannot be altered.

To use automatic retrieval you must set the 0.0m/ft position before you start the survey. To set the 0.0 position press △ and ▾ simultaneously when the crawler is in the position you wish to retrieve it to.

**NOTE: Automatic retrieval does not work when the counter is displaying a negative or zero measurement.**

To retrieve the crawler, select the RET option from the drive menu. The system will ask you to confirm the currently selected wheel size. Make sure this matches the wheel set installed on the crawler and press OK to continue.

1. Press GO to begin retrieving the crawler. The crawler will automatically stop once the cable counter reaches the 0.0 position or the Auto Stop point (if set).
2. Press CANCL to cancel the operation and return to the drive menu.

### Manual retrieval with the crank handle

If necessary, you can retrieve the crawler using the crank handle to manually wind the cable back into the drum. Before you start, disconnect the power lead to ensure that the system is not powered.

The crank socket is located under the side panel closest to the controller socket. The panel is secured with socket-head screws. Remove this panel using a metric Allen key.

Figure 5.14: Crank handle for powered drum

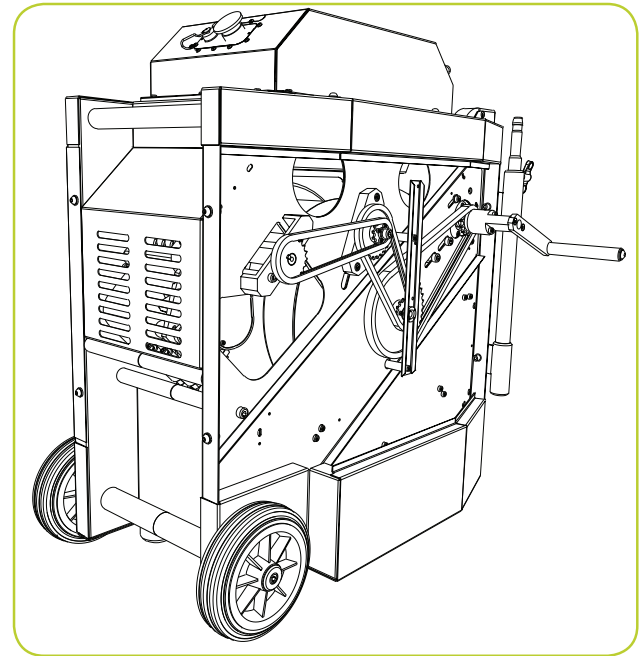

Attach the crank handle to the crank socket located in the gear on the top right-hand corner of the compartment using the supplied socket head screws.

Figure 5.14 illustrates the crank handle installed in the powered drum. Note the installation point.

**⚠ CAUTION! Remove the crank handle and replace the side panel before reconnecting power to the system.**

### 5.3.8 Steering (P356 crawler only)

**NOTE: Steering the P356 crawler is identical for both the powered and manual system.**

You can steer the P356 crawler left and right, allowing you to navigate pipes with ease. The crawler steers by changing the speed on the left or right motor.

You can steer the crawler when it is moving forwards, backwards or when it is stationary. Steering whilst reversing is possible in manual driving mode only.

**Note: Steering whilst moving is proportional to the crawler speed: the faster the crawler moves the bigger the steer.**

When the crawler is stationary, it will turn on its own axis. Be careful when turning in this fashion as the crawler may become entangled in the cable.

To steer right, press ▷. Hold the key to turn faster.

To steer left, press ◁. Hold the key to turn faster.

Whilst moving you can achieve a tighter turn by using the lock steer function.

In this mode one set of wheels will lock. This gives a tight turn, but will reduce the crawlers pulling power.

You can lock steer the crawler by pressing ALT + ◀ or ▶ at the same time.

You can stop the crawler steering at any time by pressing ▲ if stationary or moving forward or ▼ when reversing in manual mode. If the crawler is moving it will stop steering and continue to move in the same direction.

To stop turning the crawler when it is stationary you can also press (⏻) or the spacebar.

### 5.3.9 Tractor power

You can control the power to the tractor and to the camera.

From the DRIVE menu go to: SETUP->TRACT

To remove the power to the downhole equipment:

1. Press POWER
2. Press YES to remove the power or NO to cancel

**NOTE: If you power down the downhole equipment the tractor brake will be disabled and live video will be lost.**

To restore Power:

1. Press POWER

### 5.3.10 System diagnostics

The P350 system has built-in diagnostics. These run automatically at start-up and every time you enter Drive mode. If any problem is detected, a message will be displayed, describing the fault and the recommended actions to be carried out.

This is the list of faults and recommended actions:

Faults	Actions (before consulting service)
Interface module error	-
No Drum control, no video	Check for drum connected and powered, check link cable
No Drum control	Check link cable
No Tractor control, no video	Check for tractor connected, check down-hole cable, check tractor connector
No Tractor control	Check down-hole cable, check tractor connector
No camera control, no video	Check for camera connected, check camera connector

No camera control	Check camera connector
No video, no video at Drum	Check tractor connector, check down-hole cable, check camera connector
No video, video at Drum OK	Check link cable
No application running on drum/tractor/camera	Upload software
Software mismatch	Get latest software and update

Press OK to close the fault message and continue operations.

If the fault is such that you require further assistance from a service centre please make a note of the fault reported and how this developed.

The system also automatically logs all issues in a log file which can be found in the root of the CF card. The file is called **Controller\_Log.txt** and it should be made available for reference to the service personnel.

## 5.4 Video recording

Recording video is simple. Before you begin a recording, make sure you have installed a high quality Compact Flash card with sufficient free space to store your recording. Refer to Section 6 for more information about using and selecting Compact Flash cards.

**⚠ CAUTION! Do not remove the Compact Flash card or switch the command module off during the recording process. Doing so may corrupt all data on the card and cause the command module to crash.**

To begin recording press ○; a red circle will appear on-screen to indicate that a recording has begun.

If required, connect the optional headset to record audio commentary over the video.

To pause a recording, press □. Press ○ or □ button to resume your recording.

To end the recording, press □ on the keypad or press ESC on the keyboard.

**NOTE: Recordings are automatically limited to a maximum of approximately 2 hours. Recordings exceeding 2 hours will be split into multiple files.**

Pearpoint recommends limiting recordings to a maximum of 30 minutes to optimize video post-processing on a computer.

For more information about digital video, including how to set recording quality, please refer to Section 8.



## 5.5 Still pictures

You can save a screenshot of what is shown on the screen at any time, even during recording or playback of a video.

You can use these pictures in reports or just as a photographic evidence of your surveys.

To take a screenshot press the  button (please note that any recording or playback will pause whilst the picture is saved onto the Compact Flash card).

The screen will display a "Please Wait" message to indicate that the picture is being saved followed by the file name; recording or playback will resume automatically.



For information on reviewing pictures or transferring them by Bluetooth see section 6.5

**Note:** The picture taken will display exactly what is shown on the screen including any digital enhancements (zoom, pan or rotate). The on-screen display menu will not be captured.

## 5.6 Camera controls

The P350 cameras have a range of features to help you locate faults in more demanding conditions.

### 5.6.1 Lights

All cameras feature LED floodlights to help illuminate pipes and conduits. LED brightness is controlled using the brightness controls on the keypad. Press  to reduce or  to increase brightness.

If no auxiliary lighthouse is used, press the brightness keys simultaneously to toggle the lights off or switch them on to their previous level.

### 5.6.2 Auxiliary lighthouse

The camera's LEDs and the auxiliary lighthouse can be operated simultaneously or independently. If a lighthouse is connected, simultaneously pressing the brightness keys will toggle the light controls between the following modes:

- Light control: ALL. Adjust both the camera and lighthouse in series.
- Light Control: AUX. Adjust the lighthouse only.
- Light control: CAMERA. Adjust the camera only.



When selected, the light control mode will flash on-screen and fade. Use the brightness keys to adjust the lighting level.





**NOTE:** When a lighthouse is connected you cannot toggle the lights on and off using a simultaneous press of the brightness keys as this will change the control mode. To switch of the lights when a lighthouse is connected, press the button until the lights are switched off.

**⚠ WARNING! The camera and lighthouse LEDs are very powerful. Do not look directly at the LEDs or point them at other people.**

### 5.6.3 Focus

You can manually adjust the focus of P350 cameras.



To focus in or out of the FW and PT camera's subject, press Fn key and  or .



The P350-CAM-PTZ camera features automatic focus. You can adjust the focus manually using the FN and  or . To resume automatic focus mode press FN,  and  simultaneously.

**NOTE:** the P350-CAM-FW and P350-CAM-PT have a focus range of 10mm (1/2") to infinity. The P350-CAM-PTZ has a focus range of 10mm (1/2") (WIDE) to infinity.



### 5.6.4 Pan

When using the P350-CAM-FW camera you can use the pan function to digitally pan a zoomed-in picture on screen.

To pan left or right, press Fn and  or  once to pan a fixed step in that direction.



Press simultaneously Fn,  and  to reset the digital pan.



When using the P350-CAM-PT and P350-CAM-PTZ cameras you can pan from side to side, giving a wide field of vision without having to manoeuvre the whole crawler.

To pan left or right, press Fn and  or  once to start panning in that direction. Press either key again to stop the camera panning.

### 5.6.5 Tilt or rotate.

When using the P350-CAM-FW camera you can use the rotate function to digitally rotate the picture on screen.

Press  or  once to digitally rotate of a fixed step the picture clockwise or anti-clockwise

Press simultaneously  and  to reset the digital rotation.



The P350-CAM-PT and P350-CAM-PTZ cameras can rotate. When combined with the pan function, you can survey objects above and below the crawler.

To start to tilt/rotate the video on-screen clockwise press .

To start to tilt/rotate the video on-screen anti-clockwise press .

To stop rotating, press either key again.

## 5.6.6 Center

When using the P350-CAM-PT and P350-CAM-PTZ you can return the camera to the forward view, leveled position by pressing  and  simultaneously.

## 5.6.7 Zoom

The P350 system offers digital zoom capabilities when used with the P350-CAM-FW and P350-Cam-PT.

The P350-CAM-PTZ camera features a 10x optical zoom. The digital zoom is disabled when this camera is used.

To zoom in on the camera's subject, press .

To zoom out from the camera's subject, press .



To reset the zoom to x1 magnification, press  and  simultaneously.



## 5.7 Digital image controls

The P350 Command module offers sophisticated digital imaging control to allow you to manipulate the video displayed on the screen when playing back a recording or displaying a video from an external video source.

### 5.7.1 Pan

You can use the pan function to digitally pan a zoomed-in picture on screen.

To pan left or right, press Fn and  or  once to pan a fixed step in that direction.

Press simultaneously Fn,  and  to reset the digital pan.

### 5.7.2 Rotate

You can use the rotate function to digitally rotate the picture on screen.

Press  or  once to digitally rotate of a fixed step the picture clockwise or anti-clockwise

Press simultaneously  and  to reset the digital rotate.

### 5.7.3 Zoom

To zoom in press .

To zoom out press .

To reset the zoom to x1 magnification, press  and  simultaneously.

## 5.8 Pendant controller

The P350 pendant controller is an optional accessory which allows the user to control the system remotely.

Figure 5.15: Pendant controller

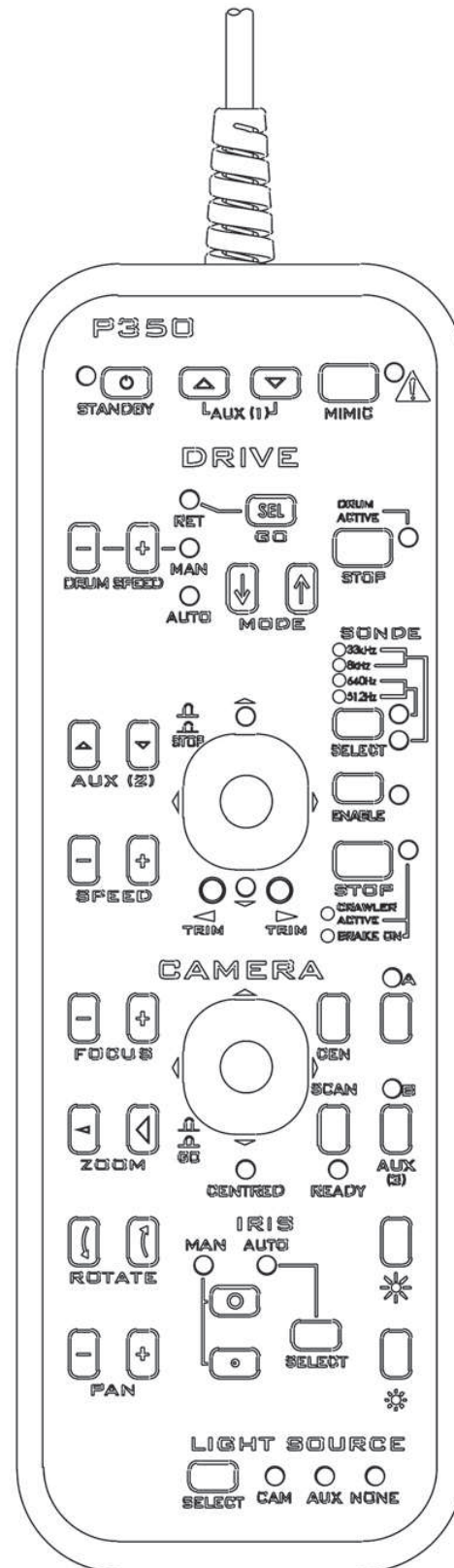

## Connections:

The P350 pendant lead connects to the pendant controller socket (item 7 in fig 2.7) on the powered drum or manual PSU.

**NOTE: Do not connect or remove the pendant controller when the P350 system is turned on.**

## STANDBY

The pendant is enabled by pressing and holding the [STANDBY] key. When the pendant is active, the pendant 'ON' indication light will turn green and the word 'pendant' will appear at the bottom of the screen on the command module. When the pendant is inactive, the 'ON' indication light will turn red.

**NOTE: To prevent inadvertent operation of the P350 system the controls on P350 command module will be disabled whilst the pendant is active. However, it is still possible to record. To return control to the command module press & hold this key.**

## Camera Controls:

### PAN

By using the [+] and [-] keys, the head can be moved up and down, or side to side, depending on the angle of the head. When used in conjunction with the rotate facility, the camera can view along different axes depending on the orientation of the head.

**NOTE: On FW cameras, this will be provided by the controllers 'soft/digital pan function'.**

### ROTATE

By using the [+] and [-] keys, the head can be rotated clockwise and anti-clockwise. If used in conjunction with the Pan facility, the effect will be to 'sweep' the view of the wall of the pipe.

Note: On FW cameras, this will be provided by the controllers 'soft/digital rotate function'.

### ZOOM

To zoom in to distant objects, press [+].

To zoom out from near objects, press [-].

**NOTE: On FW/PT cameras, this will be provided by the controllers 'soft/digital zoom function'.**

### FOCUS

To focus on distant objects, press [+].

To focus on near objects, press [-].

**NOTE: Continuous pressing of either [+] or [-] key will result in 'wrap around' of camera focus i.e. in focus – out of focus – in focus.**

## IRIS

On occasion, there may be a requirement for manual control of the iris to change the picture brightness (e.g. to reduce a reflective glint from a shiny surface). Manually opening the iris to maximum aperture will allow more light to enter the camera giving a brighter picture. Closing the iris to the minimum aperture will decrease the amount of light entering the camera giving a darker picture.

1. Press the [SELECT] key until the 'MAN' indication light comes on.
2. For a brighter picture, press the large 'O' key for the maximum aperture.
3. For a darker picture, press the small 'o' key for the minimum aperture.

## LIGHT SOURCE

The crawler lighting control allows the user to alternate & adjust intensity between camera lights, auxiliary lighthouse (if available) and no lights.

1. To select lights, press the [SELECT] key repeatedly until the appropriate indication light is illuminated.
  - a. To adjust camera lights, select the 'CAM' indication light.
  - b. To adjust auxiliary lights, select the 'AUX' indication light.
  - c. To adjust both camera & auxiliary lights in series, select the 'CAM' & 'AUX' indication lights.
  - d. To turn off all lights, select the 'NONE' indication light.

## BRIGHTNESS

Use these keys to adjust camera and/or auxiliary lighting taking note which of the above options is selected.

To increase available light, press the large 'ADD SYMBOL' key.

To decrease available light, press the small 'ADD SYMBOL' key.

**NOTE: If there is an auxiliary lighthouse fitted, and both 'CAM' & 'AUX' indicator lights are on the large 'sun' key will firstly ramp up the camera lights prior to ramping the auxiliary lights.**

## SCAN

Pressing the [SCAN] key will cause the camera to centre itself, pan 90° and roll through 360° to scan the periphery of the image. The scan can only commence if the green 'READY' indication light is illuminated. This light will not illuminate when the scan is under way.

**NOTE: This function is not available for fixed forward view cameras.**

AUX (1), AUX (2) & AUX (3)

The 'AUX' keys currently have no function. These keys are for future expansion.

## CEN

To centre the camera, press [CEN] key. Once the camera is centered the 'CENTRED' indication light will illuminate.

**NOTE: This indication light will not illuminate whilst using fixed forward view cameras.**

## MIMIC

To toggle between display states of onscreen mimic press the [MIMIC] key.

## JOYSTICK Control

Pan and tilt camera mimic is displayed when a pan & tilt camera is connected to the system. Pan and tilt camera mimic provides a two dimensional representation of a pan and tilt camera's three dimensional range of movements. The mimic cursor, represented by the square box, acts as a target, which can be positioned by pressing the joystick either left, right, up or down. Once the cursor has been placed at the desired position, depressing the [GO] button on the joystick will move the camera to point at the target.

See 5.3.4 for more information on how to use the pan and tilt mimic display.

**NOTE: Joystick function is not available for fixed forward view cameras**

## Drum & Crawler Controls:

### STOP

Pressing the bottom red [STOP] key will stop crawler motion and apply the brake in addition to turning the indication light red. The [STOP] key will toggle the brake if the crawler is not in motion.

**NOTE: When the crawler is active this indication light will be green.**

## SONDE

Pressing the [SELECT] key will disable the sonde and cycle through the four available sonde frequencies. Sonde frequency is shown on the adjacent indicator pair.

Pressing the [ENABLE] key will activate the crawlers sonde and illuminate the indication light amber.

Pressing the [ENABLE] key a second time will toggle the sonde off and the indication light will turn off.

**NOTE: The last selected sonde frequency will still be lit regardless of the sonde status as the sonde is only active if the amber indication light is on.**

## DRIVE

The 'MODE' section comprises the following controls:

Pressing the [↑] or [↓] key allows selection of the following functions:

(i) MAN (Manual). This will allow full manual control of the crawler & drum using the [+] and [-] buttons.

To increase the drum pull speed, press drum speed[-].

To decrease the drum pull speed, press drum speed[+].

**NOTE: These keys allow control of the speed of the drum when in 'MAN' (manual) mode only. When selected, the 'MAN' indication light will be illuminated.**

(ii) RET (Retrieve). Selecting 'RET' and then pressing [GO] key will cause the drum to automatically retrieve the crawler providing the correct crawler wheel size has been entered into the controller.

**NOTE: When selected, the 'RET' indication light will be illuminated.**

(iii) AUTO (Automatic). Selecting 'AUTO' will allow the crawler to pull cable from the drum as it is driven forward. In reverse, the drum will pull both cable and crawler at constant speed, providing the correct crawler wheel size has been entered into the controller,

**NOTE: When selected, the 'AUTO' indication light will be illuminated. Whilst cable is being retrieved the 'DRUM ACTIVE' indication light will illuminate green.**

### STOP

Pressing either red [STOP] key will stop all crawler motion and apply the brake. If the crawler is not in motion, pressing the [STOP] key will toggle the brake

Refer to section 5.3.6 & 5.3.7 for further information.

Improvement: No wheel size selection on retrieve as per command module

## SPEED

In manual mode

To increase the speed of the crawler, press [+].

To decrease the speed of the crawler, press [-].

## JOYSTICK Control

Pushing the joystick upwards will increase the crawler's forward speed incrementally. A sustained push of the joystick will accelerate the crawler until it reaches its maximum speed or until the joystick is released.

Conversely pulling the joystick backwards will decrease the crawler's forward speed incrementally. A sustained pull of the joystick will decelerate the crawler until it stops.

AUTO (Auto mode): Continuous pulling of the joystick will result in crawler retrieval.

MAN (Manual mode): Continuous pulling of the joystick will drive the crawler backwards.

Depressing the [STOP] button on the joystick will stop all crawler motion and apply the brake in addition to turning the indication light red.

**NOTE: A green indication light will be shown for the direction the crawler is travelling i.e. forwards or backwards.**

## STEERING (P356 only)

Pushing the joystick to the left or to the right will cause the crawler to steer in the required direction. A sustained press left or right will increase the rate of steer whilst increasing the speed of the crawler.

Note: If the crawler is steering to the left, tapping the joystick to the right will invert the crawler's heading.

Refer to section 5.3.8 for further information.

## TRIM (P356 only)

To turn the crawler using the [TRIM] keys:

Pressing the left or right trim key will increment the trim offset. For example, if you press the left trim button while the crawler is driving straight ahead, the crawler will begin to move fractionally to the left. Pressing the left key again will increase the left trim. Pressing the right trim key will now reduce the left trim. Pressing right again will cancel the trim

Trim may only be changed while the crawler is in motion.

The crawler will retain its trim setting through power cycles and on other P350 systems.

Pressing both [TRIM] keys together will cancel the trim command and the crawler will resume a straight ahead course.

## 5.9 Retrieving the crawler

To retrieve the crawler safely and securely, Pearpoint recommends using the accessory deployment tool.

Guide the crawler to an easily accessible position using the drive controls.

Prepare the grab, rods and clamp as described in Section 5.2.2 if you have not already done so.

**⚠ CAUTION: Use a rope to lift the crawler.**

1. Using the rope, lower the crawler grab tool and ensure the operating handle remains above the surface.
2. Secure the crawler grab to the crawler's chassis (or elevator if used); this may take several attempts.
3. Lock the crawler grab using the toggle clamp (see fig 5.4).
4. Test that the connection is secure by lifting the crawler using the rope.
5. If the connection is secure, lift the crawler to the surface using the rope.
6. When the crawler is on the surface and in a secure location, disengage the clamp to release the crawler.
7. Disassemble the rods.
8. Clean and disinfect the crawler, rods and crawler grab as required.

# Section 6 – File management and Transfer

The P350 flexitrax uses a Compact Flash (CF) card to store all video, images, text entries and report files. A two gigabyte card will store up to 1 hour and 45 minutes of video using the high-quality video setting (refer to Section 8 for more information about video quality and recording times).

**⚠ WARNING! Do not remove or insert the CF card when the unit is ON. Do not cycle the power when recording or playing. Failure to comply may damage the CF card and corrupt your data.**

The command module will display a warning (Figure 6.1) the first time the CF card is accessed or utilized.

Figure 6.1 Compact Flash card warning page

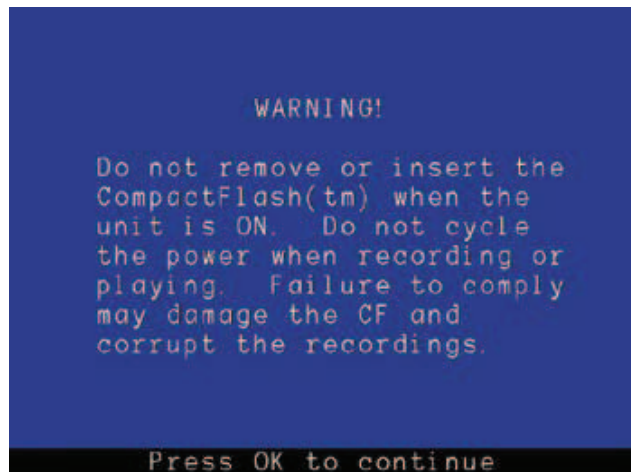

The command module provides two modes for handling compact flash cards: the CARD menu and the file browser.

The CARD menu (Section 6.1) allows you to perform general operations on the installed card.

The file browser (Section 6.3) allows you to browse and manage files and folders stored on the card.

## 6.1 CARD menu

The CARD menu allows you to set the current default directory, access reports, check the card status and format the card.

Press CARD to enter the Card Menu (Figure 6.2).

Figure 6.2: CARD menu



### 6.1.1 Destination folder

The destination folder (DESTN) menu allows you to define the default working directory where the command module will store new reports, videos and pictures.

Use this command to organize, if you wish, your survey's data in different folders: one for each job for example. See Section 6.3.1 for more information on organizing your work.

#### To create a new default folder:

1. Enter the DESTN menu.
2. Press NEW.
3. Enter a new name and press OK.

#### To set an existing folder as default:

1. Enter the DESTN menu.
2. Select a folder using the  $\Delta$  and  $\nabla$  arrows.
3. Press SET.

#### To rename the destination folder:

1. Enter the DESTN menu.
2. Select a file or folder using the  $\Delta$  and  $\nabla$  arrows.
3. Press RENAM.
4. Enter a new name and press OK.

## 6.1.2 Reports

The reports (REPOR) menu allows you to create, edit or delete reports. For more information on reports, please refer to Section 7.4.

**NOTE:** The CARD menu allows you to access any report stored on the CF card whereas the  menu allows you to edit the report saved in the current default folder only.

## 6.1.3 Card status

The Compact Flash card status window displays critical information about the state of the currently installed card. The status screen is displayed after the command module performs a series of tests to check the card's memory.

### To check your card:

1. Enter the CARD menu. Press CHECK.
2. This system will prompt you to wait and then display the card status window (Figure 6.3).

Figure 6.3: Compact Flash card status page

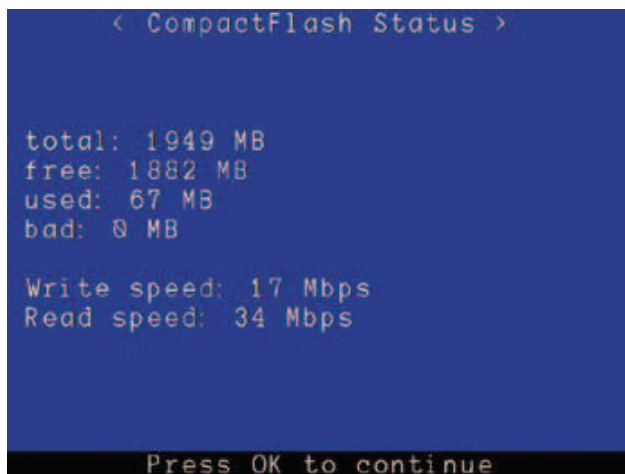

The status screen displays the following information:

- total: overall available memory in MB (megabytes).
- free: free memory in MB.
- used: used memory in MB.
- bad: bad memory in MB.
- Write Speed: write speed in Mbps (megabits per seconds).
- Read speed: read speed in Mbps.

**NOTE:** Format the Compact Flash Card if any bad sectors are found. If the Bad sector persists replace the Compact Flash card.

## 6.1.4 Formatting the card

The command module can format your Compact Flash card. If you purchase a new Compact Flash card, be sure to format it using the command module. If you format the card using your PC or Mac, format the card using the FAT32 file system.

Cards formatted in different formats or by a media player or digital camera may not work.

**NOTE:** In Mac OS X, the FAT32 file system is referred to as MS-DOS format.

**⚠ CAUTION!** Formatting the card will erase all existing data permanently; this includes reports, photos and videos. Formatting cannot be undone so proceed with caution!

### To format the card using the command module:

1. Select CARD from the Main Menu.
2. Select FMT.
3. Press YES to confirm the format operation or NO to cancel.

## 6.2 Supported card types

The P350 flexitrax system supports high-speed (40x and write speed of 6 Mbps minimum) TYPE 1 high quality Compact Flash cards with a capacity of up to sixteen gigabytes (16GB). This is the minimum requirement for high quality video recordings.

**NOTE:** There are other Compact Flash cards technical specifications that may affect a Compact Flash card's performance or compatibility with the P350 system. These specifications may not be documented by the card's manufacturer or retailer.

**⚠ WARNING:** Kingston cards are not supported due to technical compatibility issues.

For the best results, only use cards that have been formatted by the P350 flexitrax command module.

Please contact your local Pearpoint representative for the latest list of recommended cards.

Using low speed or low quality cards may degrade the video recording quality or cause the recording to hang or render the system unstable.

## 6.3 File browser

The P350 flexitrac system features a basic file manager (Figure 6.4) that allows you to create, edit and delete files and folders.

**NOTE:** Folders are sometimes referred to as directories.

**Figure 6.4: Compact Flash browser**

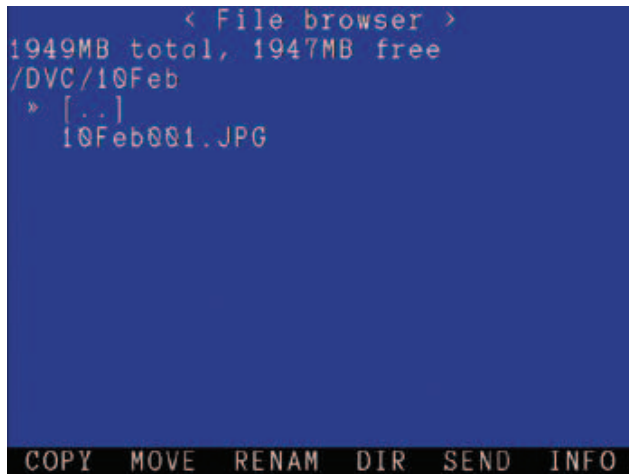

**NOTE:** You can view folders created by the P350 flexitrac in Windows Explorer or the Mac OS X Finder when you connect the command module to your computer via USB connection (see Section 6.6 for information on USB connections). The P350 card browser will only display compatible files: JPEG, MP4, TXT, BIN and HTML. BIN and HTML files are listed only and cannot be viewed on the command module.

TXT files can only be viewed if smaller than 1Mbyte.

### 6.3.1 Organizing your work

The command module automatically creates a new default folder at the start of each day's operation. The folder is named after the day it was created, for example [30Nov] and is saved in the DVC folder on the Compact Flash card.

Once created, the new folder will serve as the default location for all new videos, images and reports taken on that day. If you prefer to organize each inspection job in a different folder you can do this by manually setting a new folder (or an existing one) as the new default folder where new files are saved to (see Section 6.1.1 or 8.3.2).

For example you may wish to organize your recordings in different folders, one for each job.

**NOTE:** At startup the system will default to a directory based on today's date. For example: 01Jan for the first of January.

### 6.3.2 Filename structure





Each video, picture or pitch log file is created by the command module with the following structure: **ddmmmxxx.ext** where **dd** is the day number, **mmm** is the month, **xxx** is a counter and **ext** is the file extension.

For example: **14OCT001.MP4**.

You can customize the file name by adding a prefix to it. Refer to Section 8.3.3.

**NOTE:** File extensions on the P350 command module are case sensitive.



#### To navigate the file browser:

1. Enter the CARD menu and press OK or press the video  (play) key.
2. The command module will list any folders on the Compact Flash card; Folders are indicated by [square brackets] for example [05Nov].
3. The current location in the folder structure is shown below the Card Status line, for example /DVC indicates that your current position is in the Compact Flash card's DVC folder. The / by itself denotes the Compact Flash card's top level or root folder.
4. To enter a folder, select it with the  and  arrows and press OK or Enter.
5. The screen will now display any sub-directories and files located in the folder you selected.
6. To return to the parent folder press the  keypad arrow or select the [..] icon and press OK or Enter.

**NOTE:** The P350 File browser will only show files that are supported by the command module. These are video files and JPEG pictures created by the unit and with a MP4 and JPEG extension. HTML files are also shown but are not viewable.

### 6.3.3 Copying files

You can copy any file on the Compact Flash card to the current folder or to a different location.

1. Select the file you wish to copy using the  or  arrows.
2. Press COPY.
3. Navigate to the folder you want to copy the file to and press SEL.

**NOTE:** The command module will automatically provide a default copy name for example Copy\_of\_05Nov03.JPG. Once the file is copied, you can rename it as required.



### 6.3.4 Moving files and folders

1. Select a file or folder using the  $\triangle$  and  $\nabla$  arrows.
2. Press MOVE.
3. Navigate to the folder you want to move the file or folder to and press SEL.

### 6.3.5 Renaming files and folders

You can rename any file or folder on the Compact Flash card. The system will add the default extension automatically.

1. Select a file or folder using the  $\triangle$  and  $\nabla$  arrows.
2. Press RENAM.
3. Enter a new name and press OK.

**⚠ CAUTION! Do not rename or move any report file as this will corrupt the report and will inhibit the report conversion by FlexiSight.**

### 6.3.6 Deleting files and folders

You can delete any file and folder on the Compact Flash card using the command module.

Figure 6.5 shows the delete functions in the file browser.

Figure 6.5: File browser delete and show screen

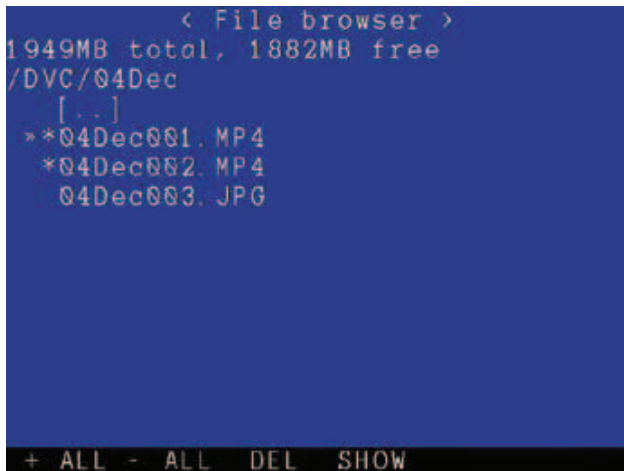

1. Select a file or folder using the  $\triangle$  and  $\nabla$  arrows.
2. Mark the file or folder by pressing the  $\triangleright$  arrow.
3. Repeat the previous two steps if you wish to delete multiple files or folders.
4. Alternatively, press +ALL to mark all the files and folders included in the current folder or -ALL to deselect them all.
5. Press DEL.
6. Select YES to confirm the delete operation or NO to cancel.

**⚠ CAUTION! This operation will delete your files. It cannot be undone!**

Note: You can also use the DEL button on the keyboard.

### 6.3.7 Creating folders

You can create new directories in any location of the Compact Flash card.

#### To create a new folder:

1. Enter the folder where you wish to create the new subfolder.
2. Select DIR.
3. Enter the new folder's name and press OK.

Once the folder is created you can move or copy files to it as with any folder on the card or set it as new default working folder. See section 6.1.1 or 8.3.2 for more details.

### 6.3.8 Sending a file with Bluetooth®:

You can send a file directly to your compatible Bluetooth® handheld device.

1. Select a file using the  $\triangle$  and  $\nabla$  arrows.
2. Press SEND.

Refer to Section 6.8 for more information on how to send files using Bluetooth®.

### 6.3.9 Information

You can access files and folders information.





1. Select a file or folder using the  $\triangle$  and  $\nabla$  arrows.
2. Press INFO to access the information:
  - File Extension or Directory
  - File Size
  - Read Only attribute
  - Hidden attribute
  - Date and time of creation
3. Press OK to continue.

## 6.4 Viewing Pitch Log

The file browser allows you to view pitch log files created by the P350 system.

**NOTE:** Pitch log TXT files can only be viewed if smaller than 1Mbyte. Larger files will have to be opened using a PC.

To view a pitch log file:





1. Select a TXT file using the  and  arrows.
2. Press OK or Enter to display the log file on-screen.
3. Press  or  or PG Up or PG Dn to scroll through the data.
4. Press OK to close the file.

## 6.5 Viewing JPEG pictures

The file browser allows you to view JPEG image files created by the P350 system. When a picture is displayed on-screen a Camera symbol will appear in the DVR section of the OSD.







**NOTE:** JPEG pictures that were not created by the P350 flexitrax system may not be compatible with the command module. Pictures will only be displayed if their horizontal and vertical dimensions are multiples of 16. For example a picture with the dimensions 720x480 pixels is acceptable whereas 800x600 pixels is not.

### To view a JPEG file:

1. Select a JPG file using the  and  arrows.
2. Press OK or Enter to display the picture on-screen.
3. Press  or  to view any other JPEGs stored in the folder.
4. Press  to return to the file browser.
5. Press W, X, A and D to pan up, down, left and right respectively. Press S to reset the panning.

### To view multiple JPEG files:



You can select more than one file to restrict your browsing to the selected one. See figure 6.5.

1. Select a JPG file using the  and  arrows.
2. Mark the file by pressing the  arrow.
3. Repeat the previous two steps for every JPEG file you wish to view or press + ALL or -ALL to select or deselct all the files present in the folder.
4. Press SHOW.
5. Use the  and  arrows to scroll through your selected images or  to return to the file browser.

## Viewing slideshows

You can display a slideshow of all pictures contained in the folder or of the multiple pictures you have selected:

1. Press SSHOW.

2. Use the  and  arrows to select your preferred transition time (3 to 20 Sec).
3. Press OK to confirm your choice and start the slideshow.
4. Press  to stop the slideshow.

## Sending a file with Bluetooth®:

As with any other small file, you can send a JPG file directly to you compatible Bluetooth® handheld device. See section 6.3.8.



You can also send a picture whilst this is displayed on the screen:

1. Select and display the picture you wish to send.
2. Press SEND.

Refer to Section 6.8 for more information on how to send files using Bluetooth®.

## Information

You can access files and folders information.





1. Select a file or folder using the  and  arrows.
2. Press INFO to access the information:
3. File Extension or Directory.
4. File Size.
5. Read Only attribute.
6. Hidden attribute.
7. Date and time of creation.
8. Press OK to continue.

## 6.6 Playing videos

You can play a recorded video and view it on the P350 flexitrax LCD or on any external monitor connected to the video output jacks on the command module, powered drum or external PSU.

**Note:** If using an external monitor to display the video, this may not display the entire picture as shown and recorded by the P350 command module. The size of the picture displayed will vary between monitors and it is dependent on the monitor's analog input and video resolution specifications.

To playback a video:

1. Use the  and  arrows to select the file you wish to playback.
2. Press  or OK to start the playback.
3. Press  to pause the video at any time.

4. Press ◀ or ▶ to FF or RW. To resume normal playback speed, press [ ] and then press video ▶.
5. Press VOL- and VOL+ to adjust the audio volume (if present).
6. Press [ ] to stop the playback and go back to the file browser.
7. Press W, X, A and D to pan up, down, left and right respectively. Press S to reset the panning.

**NOTE:** The Playback OSD will fade from view after few seconds.

You can use the digital imaging controls of the P350 command module, see Section 5.6, when playing back a video to zoom, rotate or pan the picture on screen.

**⚠ CAUTION!** Do not remove the Compact Flash card or switch the command module off during the playback process. Doing so may corrupt all data on the card and cause the command module to crash.

### 6.6.1 Screen captures

During recording or playback it is possible to capture video frames as JPEG photos. See Section 5.5 for more details.

## 6.7 USB connections

The P350 command module supports USB 2.0 to allow high speed files transfer. USB is the recommended method for transferring files between the command module and your computer.

**NOTE:** The command module is compatible with high-speed, powered USB ports. Connection to external USB hubs or older 1.1 USB ports is not recommended.

### To connect via USB:

**NOTE:** Only use USB 2.0 graded cable to connect the command module to your computer.

1. Switch the command module off for the duration of the connection. The integrated card reader will draw sufficient power from your computer's USB hub.
2. Ensure your computer is switched on and running.
3. Connect the supplied USB cable to the unit and to a free USB port on your computer. Do not use an external USB hub.
4. On Microsoft Windows-based computers, the command module will appear as a Mass Storage Device. It will be assigned with a drive letter, for

example E, and will be listed in the My Computer window.

5. On Apple Macintosh computers, the card will appear as an icon on the desktop and as a source disk in the sources list on any Finder window.
6. After your computer has mounted the card, open it in Windows Explorer or Finder and then open the DVC folder to retrieve your inspection files.

## 6.7.1 Disconnecting

**⚠ CAUTION!** The command module must be properly ejected from your computer BEFORE you disconnect the USB cable. Failure to do so may corrupt your card and all data.

### Windows

To disconnect the command module from your computer you must use the Windows USB hub manager (Figure 6.6) before removing the cable. To do so:

1. Locate the USB device icon on the Windows Task Bar (usually bottom right-hand corner of the screen). When you hover your mouse cursor over this icon, a tool tip Safely Remove Hardware will appear.
2. Left-click the icon with your mouse and click the option to remove the command module.
3. A balloon popup will inform you that it is safe to remove your hardware.
4. You can now disconnect the USB cable from the computer and command module.

**Figure 6.6:** Windows USB hub manager

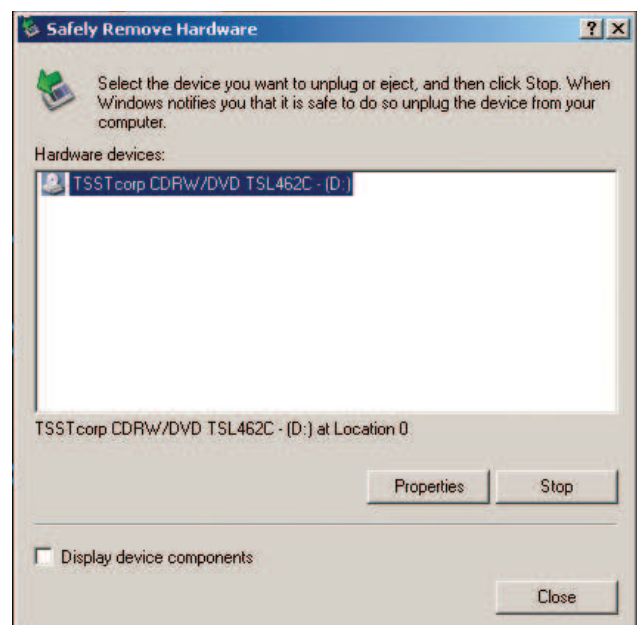

## Mac

1. Drag the card icon from your desktop to the Trash. Alternatively select the card icon and press Cmd E.
2. Wait until the icon has disappeared from your desktop or Finder window before you disconnect the USB cable.

## 6.8 Bluetooth®

The P350 flexitrac features an integrated *Bluetooth*® module that allows users to transfer files wirelessly from the P350 command module to any compatible *Bluetooth*® device such as a computer or mobile phone.

**NOTE:** Your device needs to support the *Bluetooth*® Generic Object Exchange (or OBEX) profile. Be aware that some devices only support the Headset (HSP) or Hands-Free (HFP) Profile.

See section 6.3.8 for instruction on how to select a file and send it via *Bluetooth*®.

**NOTE:** Your computer must have an integrated or USB *Bluetooth*® module to receive files from the command module. If your computer does not feature an integrated *Bluetooth*® module then you can purchase inexpensive third-party USB modules from computer hardware suppliers.

Figure 6.7: *Bluetooth*® menu

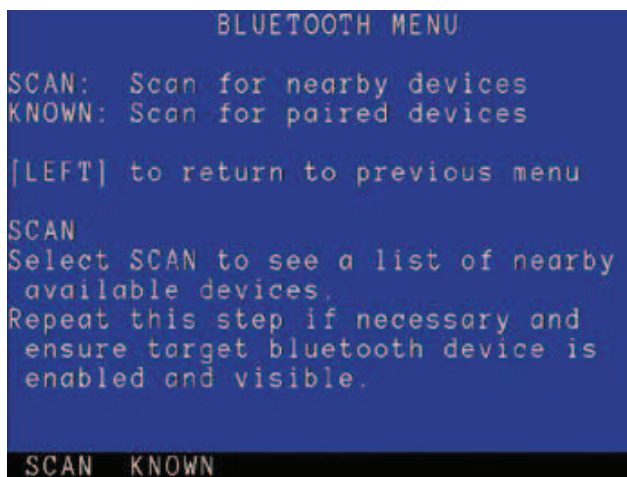

### 6.8.1 Pairing

Compatible *Bluetooth*® devices can be paired to the command module. However, pairing is not necessary to transfer a file. Pairing allows the command module to discover and connect to your device quickly in an environment where many *Bluetooth*® devices are present.

You can pair the command module to most compatible *Bluetooth*® devices, including computers, cell or mobile phones and PDAs.

### Before you pair

Before attempting to pair, make sure your device's *Bluetooth*® interface is switched on and set to visible or discoverable. Consult your device's documentation if you need help to configure your device's *Bluetooth*® settings.

### To pair your device:

1. Enter the Bluetooth menu (SETUP->COMMS->BT) or initiate a file transfer (See Figure 6.7).
2. Press SCAN to search for any nearby visible devices.
3. If your device is detected (Figure 6.8), select it using the  $\Delta$  or  $\nabla$  arrows and press PAIR. Press SCAN if you cannot see your device.
4. Your device will prompt you to enter a pass key. Enter '12345' and press Enter or OK, depending on your device's input (i.e. keyboard or keypad).
5. The system will display a message indicating if the Pairing process is successful. Press OK to return to the *Bluetooth*® menu.

The command module and your device are now paired.

**NOTE:** If you cannot see your device in the list after repeated search attempts, check that your device's *Bluetooth*® module is on and the device is set to visible or discoverable and it is within 10m (30 feet) of the command module\*. Refer to your device's manual for more information on *Bluetooth*® pairing.

\*10m is the maximum range for *Bluetooth*® connections. If you are near a Wi-Fi base station or in an area with a large electromagnetic field, your connection range may be reduced to less than 3 meters.

### To delete a Paired device:

1. Press KNOWN to search for nearby paired devices.
2. Press SCAN if you cannot see your device.
3. Select the device you wish to remove from your paired list and press DEL.
4. Press  $\triangleleft$  to return to the *Bluetooth*® menu.

### 6.8.2 Transferring files

You can transfer files to any visible or paired device.

## To transfer a file:

1. Use the file browser to select a file to transfer (see Section 6.4).
2. Select SCAN to locate any nearby visible devices. You can pair your device at this point (see Section 6.8.1).
3. Alternatively, select KNOWN to locate any nearby paired devices.
4. If you device is listed, select it and press OK or SEL.
5. The command module will now attempt to send the file to your device. Follow your device's instructions on how to receive files (if any).

Figure 6.8: *Bluetooth*® device selection page

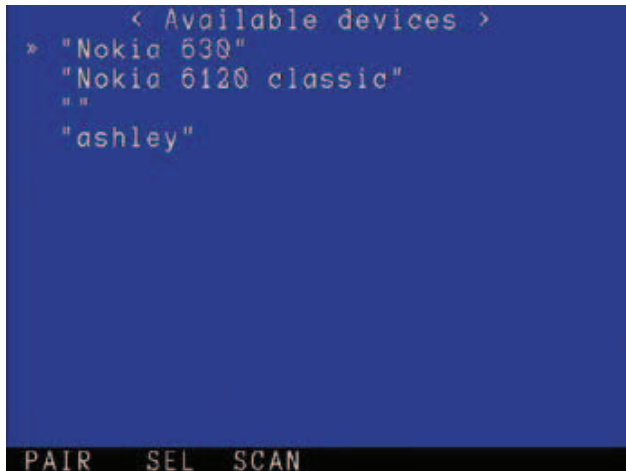

NOTE: *Bluetooth*® enabled devices such as computers and mobile phones will handle received files differently. Your device may ask you to specify the location of the received file. Some mobile phones however will automatically receive and save the file into a default location.

NOTE: Apple OS X 10.5 users must enable Bluetooth Sharing in System Preferences (see Figure 6.9) to receive files sent by the command module. The Bluetooth Sharing menu also allows you to set how OS X handles received files.

You can transfer any file on the card, however due to the limited bandwidth supported by *Bluetooth*® it is recommended that you send small files only. To transfer video files, Pearpoint recommends using the USB connection.

Figure 6.9: Mac OS X Sharing preferences

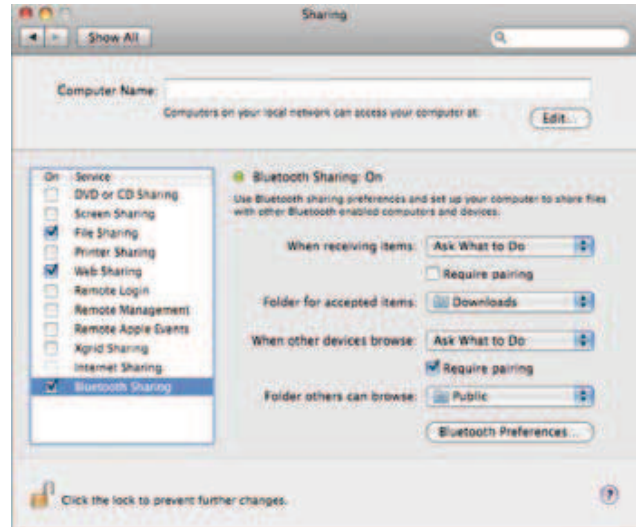

# Section 7 – Inspection reports and text pages

This section introduces the P350 flexitrax command module's integrated report writer and text page editor.

## 7.1 About reports and pages

During your survey you can choose to overlay a text page on your recording or to create a report to document your findings for audit or review.

Press  to enter the Text and Report menu (see Figure 7.1).

Figure 7.1: Text and Report menu

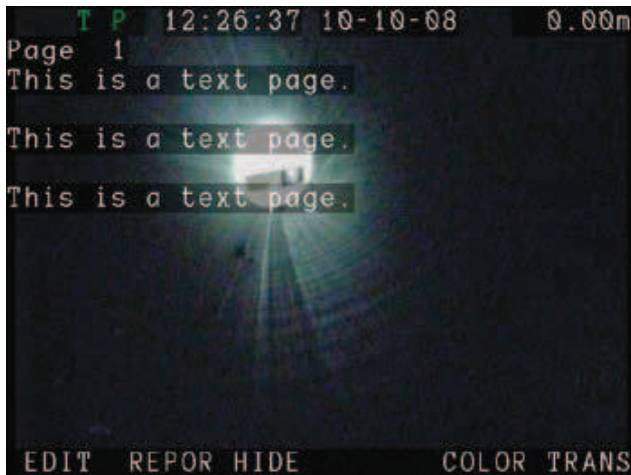

If this menu is accessed during a recording then the recording will automatically pause. The recording will resume automatically when you complete your task and exit the menu.

**NOTE:** If you are already editing a Report, pressing  will take you directly to the Report Menu. See 7.4 for more information.

## 7.2 Defect Codes

The command module supports defect codes. This feature helps you to save time and ensure consistency when you create or edit reports. You can browse a defect code list stored in a text file that is saved in root directory of your Compact Flash (CF) card.

**NOTE:** the file must be present in the root of the CF card for this to work.

Obtain the latest “defect\_codes.txt” file from the Radiodetection website or create your own. See Appendix 9.7 for more information on how to create or edit a defect codes text file.



## 7.3 Video text pages

The P350 command module allows you to create, edit and save up to 10 pages of text using the Report and Text menu. The maximum number of characters that can be entered depends on the font set used:

- Large fonts: 13 rows x 36 characters
- Small fonts: 21 rows x 45 characters

**NOTE:** Take care when editing your text pages so that the resulting video recordings display all the information required when it is converted to a DVD. See Section 8.5 for more info.

### 7.3.1 Browsing text pages

1. Use the  and  arrows or PageUp and PageDown to cycle through the pages; each page is numbered 0 to 9.

### 7.3.2 Overlay selected page

1. Press OK to overlay the selected page and to exit the Text menu.

**NOTE:** The page title is not recorded even if shown on the screen

### 7.3.3 Remove text page

1. Press HIDE to remove the current overlaid page and exit the Text menu.

### 7.3.4 Editing text pages

1. Press EDIT to modify the page currently displayed (see Figure 7.2).
2. Use the keyboard or keypad to add or edit the text:

Figure 7.2 Video text editing page

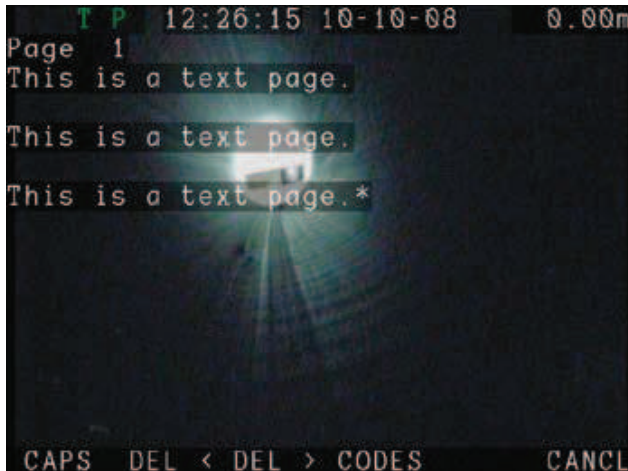

### Editing text with the keyboard

The keyboard is fully featured; you can enter any available character and use navigation keys such as Home, End and the arrow keys to position the cursor.

1. To delete all text to left of the cursor, select DEL <.
2. To delete all text to the right of the cursor, select DEL >.
3. To browse the defect codes file (if present) select CODES.
4. Press Esc to undo your changes and exit the Text menu  
or
5. Press Enter to save your changes and exit the Text menu  
or
6. Press Pg Up or PG Dn to accept your changes and select another page to modify.

### Editing text with the keypad

You can enter text with the keypad arrows. Use the  $\Delta$  or  $\nabla$  arrows to cycle through the list of available characters. Use the  $\triangleleft$  and  $\triangleright$  arrows to move the cursor backwards and forwards along the line.

1. To toggle between upper and lowercase press CAPS.
2. To delete all text to left of the cursor, select DEL <.
3. To delete all text to the right of the cursor, select DEL >.
4. To browse the defect codes file (if present) select CODES.
5. Press CANCL to undo your changes and exit the Text menu,

6. Press OK to save your changes and exit the Text menu.

### 7.3.5 Changing text appearance

You can modify the text appearance by varying character's color and transparency.

#### Color

1. Press COLOR to enter the color menu.
2. Use  $\Delta$  and  $\nabla$  to select the desired color font and press OK to confirm the choice and exit.

#### Transparency

1. Press TRANS to enter the transparency menu.
2. Use  $\Delta$  and  $\nabla$  to select the desired transparency and press OK to confirm the choice and exit.

## 7.4 Reports

The P350 flexitrax system features an integrated report writer that allows you to create inspection reports on site using the command module. The report contains your company and client details, observations, comments and selected photos captured with the P350 flexitrax camera.

Reports are generated in HTML format and are compatible with IE 6 or above. You can view or print reports using any compatible PC, by accessing the report folder on the Compact Flash card. This report can be given directly to the customer or can be converted into MS Word (Office 97 or later) for further editing.

**NOTE:** The P350 flexitrax command module cannot display a report in its final format. It will however display individual editable text entries.

Figure 7.3: Report menu

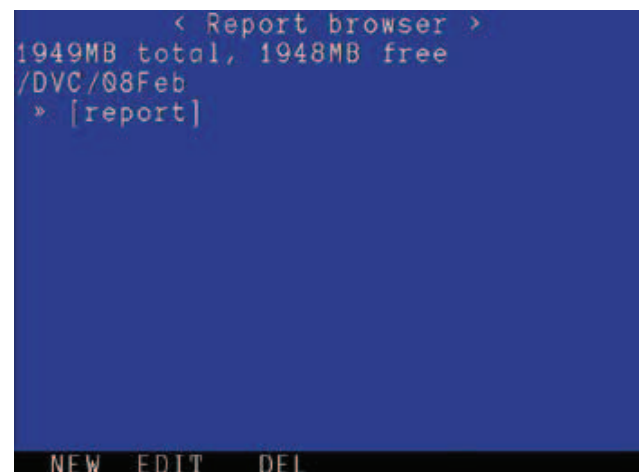

## 7.4.1 Creating a new report

### To create a new report:

1. Press REPOR to enter the report menu (Figure 7.3).
2. Select NEW to create a new report in the default working folder.

**NOTE:** You can create a new report in any other sub-folder of the DVC folder in your Compact Flash card by entering the CARD menu, selecting the sub-folder you wish to create the report in and entering the report menu.

3. Type the report's name and press OK. The system will generate a blank report using the name you specified as the report's folder.
4. Once created, the command module will present you with seven editable pages inside the report's data folder.
5. Use the  $\triangle$  and  $\nabla$  keys or type the name of the page using the keyboard to select any of the pages you wish to edit and press OK to enter them.
6. Use the  $\triangle$  and  $\nabla$  keys or enter a number with the keyboard to browse the page's fields. The bottom row of the screen will show the field content. Press OK to edit the content.
7. Once edited the field press OK
8. Press the  $\leftarrow$  key to go back to the previous menu. If pressed in the top menu it will return to the live picture.
9. At any time you can toggle between the report screen and the live video by pressing. Recording will resume automatically.
10. Press CLOSE to close the report.

**NOTE:** You need to close a report to be able to access text pages.

Figure 7.4: Report pages

```
< report >
1949MB total, 1947MB free
/DVC/08Feb/report/data
> client
  company
  freetext
  observations
  photos
  site
  survey
CLOSE
```

The seven editable pages are:

1. Client (see Section 7.4.2).
2. Company (see Section 7.4.3).
3. Freetext (see Section 7.4.4).
4. Observations (see Section 7.4.5).
5. Photos (see Section 7.4.6).
6. Site (see Section 7.4.7).
7. Survey (see Section 7.4.8).

These are detailed as follows.

### 7.4.2 Client

This page allows you to enter details about your client. You can enter your client's name, contact details and specify a reference if required.

This information appears on the Report Details page.

#### Client fields

- 1: ClientName: client's company name or personal name if the client is an individual (30 char max).
- 2: ClientRef: client's reference (30 char max).
- 3: ClientContact: name of the client's representative if applicable (30 char max).
- 4: ClientPosition: contact's position, for example manager, landlord or tenant (30 char max).
- 5: ClientAddress: client's address if different from the Site address (see Section 7.4.7) (50 char max).
- 6: ClientTel: telephone number (20 char max).
- 7: ClientMob: mobile or cellular telephone number (20 char max).
- 8: ClientEmail: email address (30 char max).

### 7.4.3 Company

This page details your company's information. If you have entered your company's details in the controller settings (see Section 4.10) before you created the report then the information is already in place. You can leave this page as it is or edit as required.

**NOTE:** Any change to your company details will not override what is already set in the main company menu setting page.

The fields are explained in Section 4.10.

Use the  $\triangle$  or  $\nabla$  keys or enter a number using the keyboard to select a field. Press OK to edit the desired field.



## 7.4.4 Freetext

In each report, you can include a page containing free form text limited to 468 characters. This is particularly useful for notes or explanations that do not fit elsewhere in the report. Set your Title in the FreeTitle field and then enter your comments in the Body field.

Free text will appear in the generated report as the final page in the document.

### Freetext fields

- 1: FreeTitle: use this field to give your comments a title. In the report, the title appears as a subheading under the Comments page title (30 char max).
- 2: Body: use this field to write your comments (468 char max).

## 7.4.5 Observations

The observations page allows you to create a sequential, annotated report of your survey. Each observation you make (limited to 20 maximum) can include a position, code, comments, the grade and a photo.

Use the  $\triangle$  or  $\nabla$  keys or enter a number using the keyboard to select an observation field. Press OK to edit the desired field.

The fields offer considerable flexibility and you can populate them with information to suit your work practices. The only exception is the ObsPhoto field, which requires you to select a photo stored on the Compact Flash card.

**NOTE: ensure to enter observations in a chronological order. Do not skip observation fields as this may affect the way the final HTML report will work**

### Observation fields:

- 1: ObsPosition: record the position of your observation (30 char max). The current counter reading is automatically entered. You can edit this if you wish.
- 2: ObsCode: enter a defect code. There are 2 mutually exclusive ways of editing this field: you can enter the defect code manually or by browsing the defect code file (if present). See Section 7.2 for more information.
- 3: ObsNotes: record your comments, such as a brief description or assessment of the observation (30 char max).
- 4: ObsGrade: grade your observation, if required. For example, you could grade an observation by severity of fault (30 char max).
- 5: ObsPhoto: add a JPEG image located in your current default directory in the Compact Flash card. The generated report will feature an in-line thumbnail of this image.

### To select a JPEG picture:

Go to the ObsPhoto field and press OK. You can select from the following options:

- SEL: Select the highlighted picture.
- SHOW: Show the highlighted picture.
- REMOV: Remove the selected picture.
  1. Use  $\triangle$  and  $\nabla$  to highlight a JPEG file from the current default directory.
  2. Use SHOW to review the picture and SEL to select it.
  3. Press OK to confirm the choice of the selected file and return to the previous directory.
  4. Use REMOV to remove the selected file.

**NOTE: An error message will appear if the picture is not suitable.**

### Observation popup

When entering observations you can set up the command module to display (popup) your observation code, notes and grade automatically for a duration of 4 seconds in the middle of the screen when resuming your survey if recording.

To enable or disable the observation popup go to DVR-> REPOR.

## 7.4.6 Photos

With the photos form you can attach annotated pictures (limited to 20 maximum) to the report.

Pictures will be shown in the generated report under the Photos Small and Large pages.

Use the  $\triangle$  or  $\nabla$  keys or enter a number using the keyboard to select a photo field. Press OK to edit the desired field.

**NOTE: ensure to enter photos in a chronological order. Do not skip photo fields as this may affect the way the final HTML report will work**

### Photos fields

- 1: PhotoName: select or show the highlighted picture.
- 2: PhotoCaption: use this field to describe the picture with caption text (30 char max).

## To select a photo

Go to the PhotoName field and press OK. You can select from the following options:

- SEL: Select the highlighted photo.
  - SHOW: Show the highlighted photo.
  - REMOV: Remove the selected photo.
1. Select a JPEG file from the current default directory using the  $\triangle$  and  $\nabla$  keys.
  2. Press SHOW to review the photo.
  3. Press SEL to select the photo.
  4. Press OK to confirm the choice of the selected file and return to the previous directory.
  5. Press REMOV to remove the selected file.

**NOTE: An error message will appear if the photo is unsuitable.**

## 7.4.7 Site page

The site page allows you to enter information about the site or location that you are surveying. This page is useful when your client's office address differs from the survey location, for example when your client is a real estate agent and the survey site is located at a letting property.

This information appears on the Report Details page.

### Site fields

- 1: SiteContact: name of the principal contact for the site (30 char max).
- 2: SitePosition: contact's position; you could enter landlord or receptionist for example (30 char max).
- 3: SiteAddress: address of the site under survey (50 char max).
- 4: SiteTel: landline telephone number of the site contact (20 char max).
- 5: SiteMob: mobile or cellular phone number of the site contact (20 char max).
- 6: SiteEmail: email of the site's contact (30 char max).

## 7.4.8 Survey

The survey page allows you to enter information about the survey you conduct.

Survey information appears on the Report Details page.

## Survey fields

- 1: Date: Date the survey took place (10 char max).
- 2: Surveyor: Surveyor's personal or company name (30 char max).
- 3: Log: Log number (30 char max).
- 4: Our Reference: Your reference number (30 char max).
- 5: Client's Reference: Customer reference number (30 char max).
- 6: Operator: Survey operator (30 char max).
- 7: Start: Survey starting point (7 char max).
- 8: Finish: Survey finishing point (7 char max).
- 9: Direction: Survey direction; choose between upstream or downstream using the and keys.
- 10: Survey Length: Length surveyed (30 char max).
- 11: Height: Manhole depth (30 char max).
- 12: Material: Pipe material (30 char max).
- 13: Size: Pipe size (30 char max).
- 14: Shape: Pipe shape (30 char max).
- 15: Water Level (30 char max).

## 7.5 Editing reports

You can edit reports at any time using the P350 command module.

**NOTE: You can also edit reports in Microsoft Word. See Section 7.8 for more information.**

### To edit the opened report:

1. Press .
2. You can now edit pages and fields as described in Section 7.4.

### To edit any report:



1. Enter the CARD menu.
2. Use the  $\triangle$  and  $\nabla$  keys to select the folder containing the report you wish to edit.
3. Press REPOR.
4. If more than one, select the report you wish to edit using the  $\triangle$  and  $\nabla$  arrows.
5. Press EDIT to edit the selected report.

6. You can now edit pages and fields as described in Section 7.4.
7. Press CLOSE to close the report.

## 7.6 Deleting reports

You can delete reports at any time using the P350 command module.

### To delete the opened report:

1. Press .
2. Press CLOSE to close the report
3. Press  and enter the REPOR menu.
4. If you have more than one report in the default working folder use  $\Delta$  and  $\nabla$  to select the one you wish to edit
5. Press DEL.
6. Press YES to confirm or NO to abort the operation.

### To delete any report:

1. Enter the CARD menu.
2. Use the  $\Delta$  and  $\nabla$  keys to select the folder containing the report you wish to delete.
3. Press REPOR.
4. If more than one, select the report you wish to edit using the  $\Delta$  and  $\nabla$  arrows.
5. Press DEL to delete the selected report.
6. Press YES to confirm or NO to abort the operation.

## 7.7 Viewing and printing reports

You can view reports on your desktop or laptop computer. Generated reports can be viewed on a computer running Microsoft Windows XP or Vista and Internet Explorer 6 or later.

### 7.7.1 Folder structure

The report is generated as a series of HTML documents organized into a number of subfolders contained in the main report folder. The principle is similar to that of an internet website. By default, the report folder is stored in the current default working folder of the Compact Flash card and is named according to the name you gave the report when you created it.

For example, 30NOV/MYReport

Reports are organized as follows:

- [MyReport]: top level report folder, named according to your preference when you created the report.
- [data]: folder containing the XML data files.
- [images] folder containing the images you attach to the report.
- [pages]: folder contains individual HTML pages.
- logo.jpg is your company or business logo. This is the logo entered in the COMPANY. You can replace this file as required.
- report.html is the main page of the report.

**NOTE:** Please take care to copy or move the entire report folder (including all sub-folders) to your computer when retrieving the report from the Compact Flash card. The report folder contains multiple sub-directories that are required for viewing and converting the report.

**CAUTION!** Do not edit any files directly with a text editor or word processor as this may corrupt the report or render it unreadable to FlexiSight.

### 7.7.2 Browsing and printing

Figure 7.5: Viewing reports in Internet Explorer

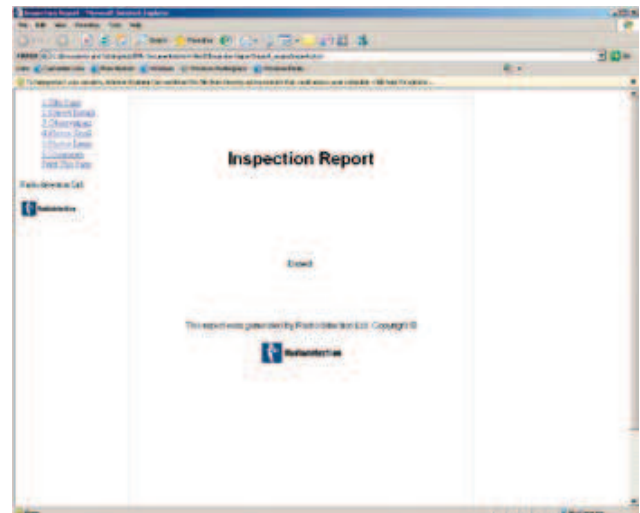

1. Connect the command module to your computer using the supplied USB cable.
2. Once your computer recognizes the command module, use Windows Explorer to locate the report folder.
3. You can then copy or move the report folder to your computer or view it directly from the Compact Flash card.
4. Using Windows Explorer locate the report.html file in the report folder.

5. Open “report.html” with Internet Explorer.
6. If prompted, allow Active Content by right-clicking the yellow warning bar and select the ‘Allow Active Content’ option.
7. The report will load and display the navigation frame on the left and the title page on the right.

To assist navigation, the report is presented in a similar fashion to a web site or a PDF document with bookmarks (Figure 7.5).

The report is divided into two frames:

- The navigation frame (Figure 7.6) on the left displays a link to each page and a print link that prints the currently displayed page.
- The content frame on the right displays the currently selected report page.

To print a page, select it using the links on the navigation frame and then press the [Print This Page](#) link. You must repeat this step for each page of the report.

**Figure 7.6: Report Navigation**



**NOTE:** Use the [Print This Page](#) link rather than using the File -> Print command, otherwise the printed page will also include the navigation frame and be printed in landscape format.

## 7.8 Exporting reports to Word

FlexiSight is a Windows-based application bundled with the P350 flexitrax system that allows you edit video and convert reports to Microsoft Word format. This section provides help on using the report conversion function. For instructions on how to use FlexiSight to edit your videos, please consult the FlexiSight help.

You can use FlexiSight to convert the inspection report to a single Microsoft Word document. Once converted to Word format, you can edit the report as you wish.

**NOTE:** FlexiSight does not overwrite the original report data so if you accidentally delete your text you can re-import the original HTML report and create a new Word document.

Once you convert the report to a Word document, you can save the report to any file format your word processor supports.

### 7.8.1 Conversion requirements

To convert an inspection report to Microsoft Word format, you need the following system requirements.

- Microsoft Windows XP with Service Pack 2 or 3.
- Microsoft Office 97 or later.
- FlexiSight 2 or later.

### 7.8.2 Conversion overview

FlexiSight will convert the HTML report to a single document. By default a report has 6 sections, which are detailed as follows:

- Title page: title and date of report.
- Report details: includes Survey, Company, Client and Site details.
- Observations: details the observations you made while in situ and includes thumbnail images.
- Photos Small: shows captioned photos in a small size.
- Photos Large: shows captioned photos in a large size.
- Comments: free form text comments.

Once the conversion is complete, you can edit and modify any part of the report. This is particularly useful if you need to expand or include new comments and observations or correct any spelling mistakes. You can also change typefaces or styles to reflect your company’s house style and position graphics and logos accordingly.

### Converting to Microsoft Word format

**NOTE:** Close all open Microsoft Word documents before you begin the conversion process.

1. Connect the command module to your computer using the supplied USB cable. See Section 6.7.
2. Navigate to the folder where your report is located and copy the folder to your computer.
3. Open FlexiSight.
4. Click Report on the menu bar.
5. Use the file browser (Figure 7.7) to select the report folder and click OK.

- FlexiSight will open Word and initiate the conversion. When the process is complete the document will be available in Word.

**Figure 7.7: FlexiSight Report select box**

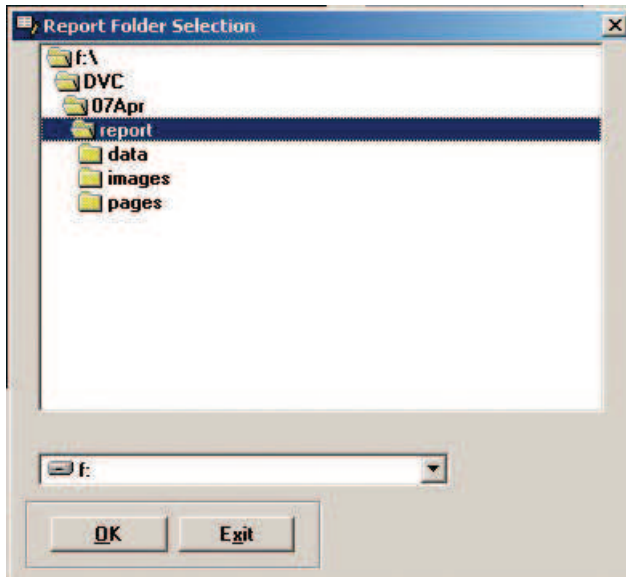

### 7.8.3 Conversion troubleshooting

FlexiSight will not open a folder that contains missing or damaged report data files. Make sure that you copy the whole report folder to your computer before attempting to convert the report.

Do not manually edit report XML data files as this may render the report unreadable to FlexiSight. If you need to amend your report, do so using the command module's report editing feature or edit the converted report using Microsoft Word.

### 7.8.4 Customizing the Word template

FlexiSight uses a standard Word document template to create Word versions of inspection reports. If required, you can modify this template to change the design of the converted report to suit your company's house style.

The template is located in the FlexiSight installation directory, which by default is located in the Program Files directory on your computer. You can edit this template in Word and resave the document as a .DOT file.

Before attempting to edit this document, it is recommended that you back up the original file.

If you choose to edit the template, make sure you do not edit or delete any of the data codes stored in the document. FlexiSight uses these codes to properly embed report data into the generated document.

# Section 8 – Digital Video

The P350 flexitrax incorporates an advanced digital video recorder. This section provides an overview of the P350 flexitrax digital video recording and playback capabilities. Also included is a detailed section on converting video files to other popular formats for playback and distribution.

## 8.1 Video Specification

The P350 flexitrax system produces high-quality digital video files encoded with H.264 video and AAC audio CODECs. The resulting files have an MP4 extension.

## 8.2 Video quality Settings

The P350 flexitrax can record video using several predefined quality settings. The system also allows you to configure video quality settings to suit your requirements.

The P350 flexitrax includes three predefined video quality settings. Video quality is set using the DVR Record Settings menu. The High quality setting provides high quality recordings but produces larger file sizes, which reduces the number of recordable hours per gigabyte. The medium and low quality settings produce smaller file sizes and provide more recording hours per gigabyte.

### To select a predefined quality setting:

1. Enter the DVR menu.
2. Select QUAL and then choose High, Medium or Low quality video as required (Figure 8.1).

The table below provides an overview of the predefined video quality settings.

**Table 8.1: Video Quality profiles**

Property	Video Quality Profiles			
	High quality	Medium quality	Low quality	Custom
Frame size	VGA	VGA	QVGA	user defined
Bitrate	High	Medium	Low	user defined
Encoding	Progressive half	Progressive half	Progressive half	user defined
Framerate	Maximum (full)	Maximum (full)	Maximum (full)	user defined
Recording Time hrs*	1:45	3:45**	9:00**	varies

\*Approximate recording time based on 2GB Compact Flash Card

\*\* Recordings exceeding 2 hours in length are split into multiple files

**Figure 8.1: DVR Record settings menu**



**Figure 8.2: Advanced video settings menu**

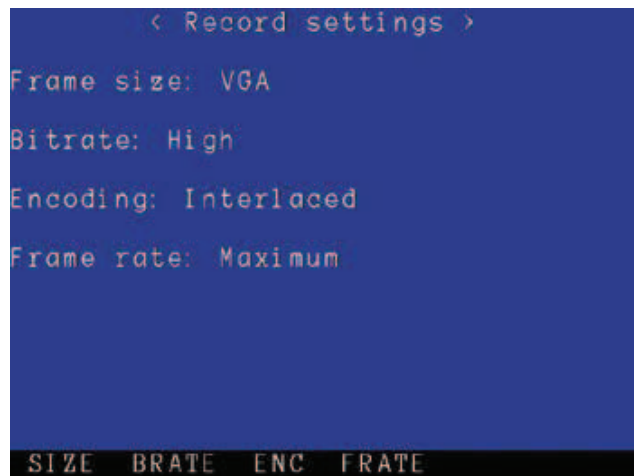

## 8.2.1 Custom quality settings

In most circumstances, the predefined quality profiles are sufficient. However, you can define your own quality settings to suit your recording requirements. To adjust the video quality settings select the ADV option under the DVR quality menu (Figure 8.1).

The Advanced Recording menu (Figure 8.2) allows you to set the Frame Size, Bitrate, Encoding and the Frame Rate.

### Frame size

The frame size (SIZE) menu allows you to select the dimensions (in pixels) of the recorded video. Your options are:

- Full: PAL (720x576 pixels) or NTSC (720x480 pixels) depending on your camera.
  - VGA: 640x480 pixels.
  - QVGA: Quarter VGA, 352x288 pixels.
1. Use  $\triangle$  and  $\nabla$  to select your choice.
  2. Press OK to confirm or  $\triangleleft$  to return to the settings menu.

### Bitrate

Bitrate (BRATE) sets the bitrate (memory usage in megabits (Mb) per second of recording). Select between High, Medium and Low.

1. Use  $\triangle$  and  $\nabla$  to select your choice.
2. Press OK to confirm or  $\triangleleft$  to return to the settings menu.

### Encoding

Encoding (ENC) sets the encoding. Select between Progressive Full, Progressive Half or Interlaced.

1. Use  $\triangle$  and  $\nabla$  to select your choice.
2. Press OK to confirm or  $\triangleleft$  to return to the settings menu.

**NOTE: Selecting interlaced will create better quality video but it will not play on a PC unless a suitable CODEC is installed. FlexiSight supports only progressive encoding.**

### Frame rate

The frame rate (FRATE) option sets the amount of frames per second. Select between:

- Maximum (30FPS for NTSC and 25FPS for PAL).
- Medium (20FPS).
- Minimum (10FPS).

1. Use  $\triangle$  and  $\nabla$  to select your choice.
2. Press OK to confirm or  $\triangleleft$  to return to the settings menu.

**NOTE: Bitrate is the only parameter that will affect your recording sizes. Higher bitrates will result in better video quality and larger file sizes.**

## 8.3 Advanced video options

The P350 flexitrax features several advanced video settings. You can for example, change the default destination and file names for recorded videos. You can also choose to include a title page on the start of each video.

Advanced video options are available in the DVR options menu.

### 8.3.1 INPUT

The input menu (DVR -> INPUT) allows you to set the video source for display and recording.

There are 3 choices: Auto, Camera and External. The default setting is Auto.

1. Use  $\triangle$  and  $\nabla$  to select your choice.
2. Press OK to confirm or  $\triangleleft$  to return to the settings menu.

The Auto setting gives preference to the external video source (if present).

The Camera setting selects the P350 camera as the default video source.

The External setting selects the external video source.

You can connect an external video source to the command module or powered drum or manual PSU using standard composite RCA or BNC cables as required.

The command module's video input jack is located inside the I/O interface panel (Item 8 in Figure 2.3) and is highlighted with a yellow ring around the jack.

The powered drum or manual PSU's video input jack is located on the connection panel (Item 9 in Figure 2.7) and identified by the text: VIDEO IN. If the selected video source is not present the P350 Command Module will show a Color Bar display. Check your settings and/or connections to the video source if this happens.

**⚠ CAUTION: Only one external video source should be connected at any time or the system will not work correctly.**

## 8.3.2 DESTN

The destination menu (DVR -> DESTN) allows you to set the destination folder on the Compact Flash card for new video recordings, pictures and reports.

Use this command to organize, if you wish, your survey's data in different folders: one for each job for example. See Section 6.3.1 for more information on organizing your work.

**NOTE:** At startup the system will default to a directory based on today's date. For example: 01Jan for the first of January

### To create a new directory

1. You can create a new folder by selecting NEW.
2. Type the new folder name and press OK.
3. Press CANCL to abort.

### To set the destination:

1. Use  $\triangle$  and  $\nabla$  to select the folder you wish to use.
2. Press SET to use the selected folder as default working folder.

### To rename a directory:

1. Use  $\triangle$  and  $\nabla$  to select the folder you wish to rename.
2. Press RENAM.
3. Type the new folder name and press OK.
4. Press CANCL to abort.

**NOTE:** The command module will display an error message if the folder name already exists.

## 8.3.3 FNAME

The File Name menu (DVR -> FNAME) allows you to append a prefix to new video or picture files.

Use this command to personalize your video recordings and still pictures.

To create a file name prefix, enter the FNAME menu and type the prefix, limited to 7 characters.

New files will have the following structure:

- **prefixddmmmxxx.ext.**

For example, CREW1\_30NOV001.MP4 where CREW1\_ is the prefix and 30NOV001.MP4 is the timestamp and extension included by default (see Section 6.3.2).

## 8.4 Video playback

You can play recorded video using the command module or any computer system that has compatible video playback software and CODECs installed.

### 8.4.1 Command module playback

Video playback using the command module is described in Section 6.6.

### 8.4.2 Computer playback

Videos can be transferred and played on any compatible computer that features the following:

- Correctly installed video and audio CODECs and a compatible video player program.

or

- A compatible video player program with integrated H.264 and AAC CODECs.

VLC (from the Videolan project) or Quicktime (from Apple) support files created with the P350 command module. Both VLC and Quicktime do not require additional CODECs and are available free for Microsoft Windows XP, Windows Vista, Mac OS X and most Linux distributions (VLC only).

VLC media player is available on line from the VideoLan project website.

Quicktime media player is available on line from the Apple website.

**NOTE:** VLC contains the libdvdcss software library, which may be prohibited for use in your country. Note however that libdvdcss is not required to play videos recorded by the P350 flexitrax. Please seek appropriate legal advice before downloading and using VLC.

### Playback on Microsoft Windows Media Player

By default, Microsoft Windows Media Player cannot play the MP4 video files created by the P350 system as it requires additional video and audio CODECs to be installed.

You can install the correct CODECs for playback on Microsoft Windows XP or Vista by installing FlexiSight. Once installed, you can play the files using Windows Media Player.

**⚠ CAUTION: FlexiSight utilizes professional video and audio CODECs which are licensed for one concurrent installation only. It is illegal to install FlexiSight on more than one computer at any time and to copy or distribute it.**



Your computer may already have third party H264 and AAC CODECs installed. While these may enable playback using Windows Media Player (or other playback software) they may inadvertently affect the performance of FlexiSight and your computer.

This is known as CODEC conflict. CODEC conflict may cause your video program or your entire system to become unstable or even crash. If you suspect a CODEC conflict has occurred, uninstall FlexiSight and all third party H.264 and AAC CODECs then reinstall FlexiSight.

CODEC conflicts can be troubleshot using a number of online free tools. Tools like *GSPOT* or *Sherlock: The Codec Detective* will allow you to see which CODECs you have installed on your PC and if they can play MP4 (H264/AAC) files.

Alternatively use a dedicated videoplayer that supports H264/AAC files.

**Figure 8.3: Video playback on Windows XP using VLC media player**

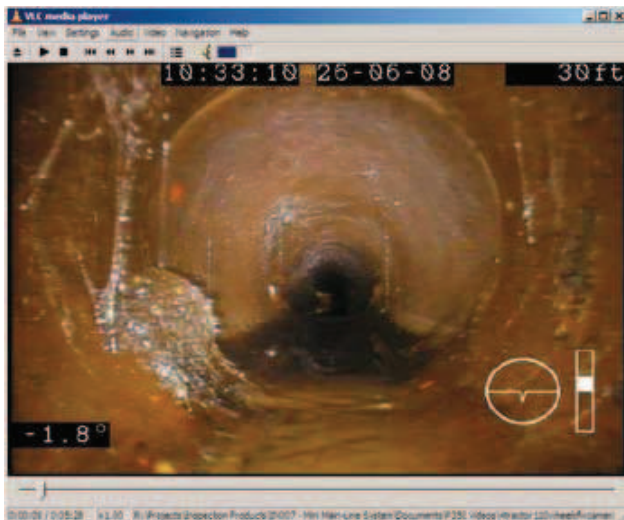

## 8.5 Distributing your recordings

When it comes to distributing your recordings the first thing to consider is your customer's requirements.

Generally speaking there are two possibilities: they may require a DVD or a digital video file.

- DVDs are one of the most popular ways to distribute videos. Domestic DVD players are found in most households and modern PCs are equipped with a DVD player.
- Digital video files are quickly becoming very popular as they can be easily edited and digitally stored on company servers. More advanced DVD players can also play some video files. Digital video files can be distributed on CDs, DVDs, flash memory or even electronically via the internet.

Once you decide on the distribution media you must know if they will play their video (DVD or digital file) on a television or a PC.

Most televisions, even modern LCDs, and standalone DVD players and recorders are designed for standard broadcasting. As such they may be unable to display or record the video produced by the P350 command module correctly. This is because the P350 makes use of the entire 4:3 video picture available, whereas standard broadcasts usually do not.

**NOTE: 4:3 refers to the standard aspect ratio of PAL and NTSC broadcasts priors to the advent of standard and high definition widescreen broadcasts.**

Depending on the implementation of overscan (the ability to display the entire 4:3 picture space), different TVs and DVD players will show different video sizes varying between the full 4:3 picture and the broadcasting Graphics safe areas.

The 4:3 Action Safe area is defined to be between 3.3% and 3.5% smaller than the 4:3 full video size. The 4:3 Graphics Safe area is defined to be between 5% and 6.7% smaller than the 4:3 full video size. This is illustrated in Figure 8.4.

**Figure 8.4: 4:3 aspect ratio video space usage**

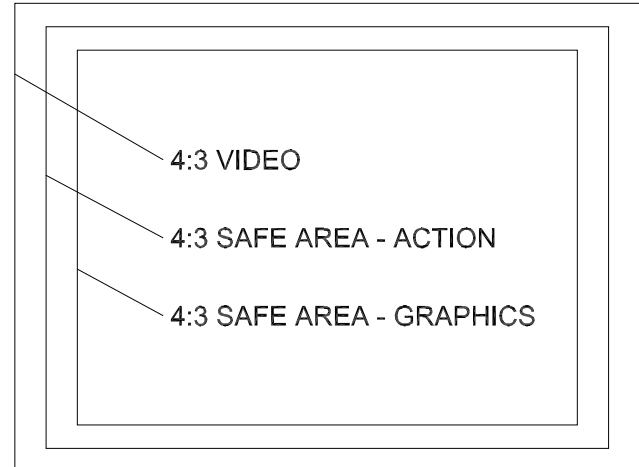

The P350 Command Module offers a number of different OSD and text layouts that will optimize your video recordings and analog video output signals to suit your desired target audience.

## Setting the P350 for PC or TV screen:

To produce a DVD or digital video file recording to be played on a TV screen set your OSD layout to TV layout.

To produce a DVD or digital video file recording to be played on a PC screen set your OSD layout to Normal layout.

See Section 4.5.2 for more information on how to set OSD layouts.

### 8.5.1 Producing a DVD video

The quickest ways to produce a DVD disc from a P350 recording are:

- using a DVD recorder
- or
- using a PC or Mac computer.

#### Using a DVD recorder

If you have a domestic DVD recorder with composite video inputs, you can copy the video direct to a blank DVD using the following procedure:

1. Ensure you have recorded your survey with the OSD set to TV layout.
2. Connect any of the P350 flexitrax video outputs to your DVD recorder's video input sockets using a suitable composite video cable.
3. Switch on the command module and locate the file you wish to convert using the file browser. Do not play the file at this stage.
4. Insert a blank DVD into the DVD recorder and begin recording.
5. Play the file on the command module.

**Note:** if your recordings were not set to TV mode use the digital zoom function on the command module to match the P350 video picture size to the one captured by your DVD recorder and displayed by your TV.

6. When the file is finished playing, stop the DVD writer and, if required, finalize the DVD disc following the DVD recorder's user documentation.

## Using a PC or Mac computer

To produce a video DVD using a PC or Mac you will need a computer equipped with a DVD burner and a compatible authoring program.

Nero 8 or later and Xilisoft's DVD Creator supports H264/AAC recordings for Windows based PCs. Roxio Toast is available for Mac Users.

These programs feature easy-to-use wizards that guide you through the conversion and burning process.

To produce your DVD just select the MP4 recording that you want to convert and select the DVD Video creation function.

**NOTE:** You will have to set the OSD layout to TV before recording your survey in order to ensure that resulting DVD will play on a TV.

### 8.5.2 Supported digital video files

#### H264/AAC MP4 files

The flexitrax system creates MP4 files which are encoded in H.264 for the video and AAC for the audio.

If you decide to distribute MP4 files created with the flexitrax system you must ensure that your customer is able to play the files on his computer. To do this your customer must have the right CODECs installed or a dedicated digital video player that supports both CODECs.

Alternatively you may distribute (subject to licensing) a suitable third-party media player or the relevant CODECS with your recordings.

See Section 8.4.2 for more information on playing back on a PC.

#### MP42/WMA2 AVI files

Your customer may require a different file format. The most commonly used is an AVI file encoded in MP42 for the video and WMA2 for the audio. AVI files encoded in this way are usually supported by Windows without the need of any additional CODECs.

You can create such a file by using FlexiSight, if installed on a PC running Windows XP. Just open the original MP4 file and save it as an AVI file by selecting the file type required in the "save as" dialog box.

Please note that FlexiSight will re-encode the original video. The operation will take some time and the resulting video quality will be inferior to the original file. The length of the final file may also be much larger depending on the complexity of the video.

### 8.5.3 Unsupported digital video files

**⚠ CAUTION: Producing formats other than those described in Section 8.5.2 is not supported by Pearpoint. The information here is intended as a general guide only.**

In order to produce a different video digital file you will have to use a video conversion application to re-encode your file.

Video conversion software gives considerable control over many video properties, allowing you to create files that best suit your requirements.

On Microsoft Windows systems, third-party applications like the “Ultimate” video converter offered by Xilisoft (commercial) or Super© (free), both available on the web, can convert P350 MP4 files into many other digital video formats.

For an introduction on converting P350 videos to different (unsupported) formats using a computer, please refer to Section 8.6.

#### DivX and Xvid AVI files

A popular file format supported by many newer DVD players and many portable digital players is DivX. You can re-encode our files in AVI DivX by using a suitable video converter.

DivX CODECs for Windows and Mac are available to download freely for personal use.

Xvid is an open source implementation of the DivX CODEC. Most Xvid encoded files will play on a DivX certified player.

The advantages of this format are:

- Good quality at reduced file size.
- Wide playability with digital media players and some domestic DVD players.
- Does not require a DVD or CD burner to produce.

The disadvantages of this format are:

- Encoding process can take longer than other formats.
- Requires a suitable CODEC or a compatible media player to play on computers.

#### QuickTime MOV files

The QuickTime format is based on a similar H.264 CODEC as the native P350 video format, thus it enjoys the same quality to file size ratio. The QuickTime format is playable on PC and Mac computers using Apple’s QuickTime media player.

The advantages of this format are:

- Good file size to quality ratio.
- Preferred video file format for Apple Mac computers.
- Playable on Apple’s ubiquitous personal media players and smartphones.
- Is suitable for embedding in web pages for distribution on the internet.
- Does not require a DVD or CD burner to produce.

The disadvantages of this format are:

- Encoding process can take up to three times longer than other formats.
- Requires QuickTime or the VLC media player for playback on a computer.
- Is not playable on domestic DVD players.

### 8.5.4 Using data CDs, DVDs and USB flash drives

You can copy any digital video file on to a standard, blank data DVD or CD using any burning program that is compatible with your computer.

**NOTE: If using an Apple Mac, be sure that you encode your DVD using the Joliet file system for maximum compatibility with Windows-based computers. Windows cannot read DVDs encoded with the native Mac HFS file system.**

Alternatively you can distribute your video files using a standard USB memory stick. These devices are inexpensive and can offer storage capacities greater than DVDs. These devices are simple to use and do not require the use of a DVD or CD burner only a free USB port on your computer.

**NOTE: For maximum compatibility between computers and other devices, ensure your USB memory stick is encoded using the FAT32 file system. Individual files stored on FAT32 formatted drives must not exceed 4GB in size; the total of all file sizes may be greater than 4GB.**

## 8.6 Converting digital videos

**⚠ CAUTION:** Producing formats other than those described in Section 8.5.2 is not supported by Pearpoint. The information here is intended as a general guide only.

Digital conversion requires the use of a computer to convert the video files from their native format to another digital file format.

Using this method you can convert video files to almost any format you require, for example:

- DivX / Xvid.
- VCD / MPEG1
- QuickTime.
- Flash Video (FLV).
- Windows Media Video (WMV).

### 8.6.1 System requirements

Below is a list of recommended minimum specifications for converting and editing digital video files on Windows and Apple Mac computers.

#### Windows

- Windows XP or Windows Vista.
- An Intel Pentium 4 or AMD Athlon 64 processor or higher.
- 512MB of RAM (1GB if using Vista).
- CD or DVD burner (for producing DVDs, VCDs or distributing video files on optical media).
- Video conversion software.

#### Mac

- Mac OS X 10.4 or later.
- Any G5 or Intel processor.
- 512MB of RAM (1GB if using 10.5).
- CD or DVD burner (for producing DVDs, VCDs or distributing video files on optical media).
- Video conversion software.

## 8.6.2 Conversion software for Windows

### Ultimate Video Converter

The Ultimate Video Converter is a commercial utility that can convert video files using internal CODECs. The Ultimate Video Converter is available for purchase for Windows and Mac computers from the xilisoft web site. The Ultimate Video Converter can convert P350 video recordings into the following formats:

- MPEG-1.
- MPEG-2.
- MPEG-4.
- VCD.
- SVCD.
- DVD.
- DivX / Xvid.
- WMV.
- Flash Video.
- QuickTime.
- DV (see Section 8.7.2).

### Super ©

Super © is a freeware utility for Microsoft Windows XP and Vista that can convert video files using internally bundled CODECs. Super © is available for download from the erightssoft website. Super © can convert P350 video recordings into the following formats:

- MPEG-1.
- MPEG-2.
- MPEG-4.
- VCD.
- SVCD.
- DVD.
- DivX / Xvid.
- WMV.
- Flash Video.
- QuickTime.
- DV (see Section 8.7.2).

**⚠ CAUTION:** Super© contains several software libraries, such as libdvdcss, which may be prohibited in your country. Seek appropriate advice before downloading this program.

## 8.6.3 Conversion software for Mac OS X

### ffmpegX

ffmpegX is a freeware utility that utilizes the open-source video libraries embedded in Mac OS X. ffmpegX is available for download from the ffmpegX website. ffmpegX can convert P350 video recordings into the following formats:

- MPEG-1.
- MPEG-2.
- MPEG-4.
- VCD.
- SVCD.
- DVD.
- DivX / Xvid.
- QuickTime.
- Flash Video.
- DV (see Section 8.7.2).

To convert P350 video using ffmpegX, please consult the application's online help which is available on the ffmpegX website.

## 8.7 Advanced video editing

### 8.7.1 FlexiSight

FlexiSight is a Pearpoint PC application that can perform basic editing on P350 video files. This program is compatible with Windows XP and Vista only.

FlexiSight allows basic editing only. With FlexiSight you can take and annotate snapshots, delete footage and merge clips. For more information on using FlexiSight, please refer to the FlexiSight online help.

**NOTE: The CODECs installed by FlexiSight do not support MP4 videos encoded with interlacing.**

### 8.7.2 DV

DV, or raw digital video format, is an uncompressed video file format that is commonly used in consumer digital camcorders and professional recording equipment.

The advantages of this format are:

- Cross-platform format.
- Very easy to edit, cut and composite video.
- Can be converted to almost any distribution format such as DVD or DivX.

The disadvantages of this format are:

- File sizes are very large.
- Not suited for distribution.
- Editing software can be expensive and difficult to learn.

### Converting to DV format

You can convert to DV format in two ways: analog or digital. To make an analog conversion you need video recording equipment with analog video inputs that has the ability to record to DV.

To make a digital conversion you need to copy your video files to your computer and use conversion software to create a DV version of your video file. Both Super C and ffmpegX can convert P350 video files to DV format.

**NOTE: DV video files are up to 10 times the size of compressed video formats. Ensure you have sufficient hard-drive space before you attempt to convert to DV format.**

### Editing DV

The DV format is widely supported on many consumer and professional non-linear digital video editing software. Below is a list of programs that support the editing of DV files:

- Apple iMovie HD 6 and iMovie 08 (Bundled with the iLife suite).
- Apple Final Cut Express and Final Cut Pro.
- Adobe Premiere Elements and Adobe Premiere Pro.
- Windows Movie Maker (Free with Windows XP).
- Windows DVD Maker (Free with Windows Vista).

**NOTE: Editing DV files in non-linear editing programs is a complex process that is beyond the scope of this manual. The programs listed above are well documented and feature introductory tutorials. Please refer to these before you attempt to edit your video.**

# Section 9 – Appendix

## 9.1 Shortcuts

This appendix includes a list of keypad and keyboard shortcuts featured on the command module. Familiarizing yourself with the shortcuts will allow you to work more efficiently.

You can access a list of available shortcuts by pressing **Fn + F2** on the keypad or **SHIFT + F2** on the keyboard.

**Table 9.1: Miscellaneous commands and shortcuts**

Keypad key		Keyboard key		Description
Fn +	F1	Shift +	F1	Help
Fn +	F2	Shift +	F2	List all shortcuts
Fn +	F4	Shift +	F4	Software versions screen
Fn +	F5	Shift +	F5	Sonde on/off
Fn +	F6	Shift +	F6	Jump to top menu (when possible)
			F9	Enter counter value
	△▽		F10	Calibrate / zero counter
			H	Switch Mimic on / off
			P	Start / stop Pitch Profiler
Fn +	△	Ctrl +	↑	Decrease drum rate of pull (manual mode only)
Fn +	▽	Ctrl +	↓	Increase drum rate of pull (manual mode only)

**Table 9.2: Crawler commands and shortcuts**

Keypad key	Keyboard key	Description
△	↑	Drive forward
▽	↓	Drive backward
◀	←	Steer left (P356 crawler only)
▶	→	Steer right (P356 crawler only)
	Ctrl + C	Motion Stop
	Alt + ←	Lock steer left
	Alt + →	Lock steer right

	Ctrl +	←	Trim left
	Ctrl +	→	Trim right
		M	Switch drive mode (MAN / AUTO)
		Space-bar	Motion Stop (Drive mode only)

**Table 9.3: Camera commands and shortcuts**

Keypad key	Keyboard key	Description
	F7	Light –
	F8	Light +
	Ctrl + B	Iris close
	Ctrl + D	Light switch
	Ctrl + F	Pan reset
	Ctrl + G	Pan right
	Ctrl + H	Pan left
	Ctrl + I	Rotate clockwise
	Ctrl + J	Zoom reset
	Ctrl + K	Zoom out
	Ctrl + L	Zoom in
	Ctrl + N	Iris open
	Ctrl + O	Rotate anti-clockwise
	Ctrl + T	Focus in
	Ctrl + U	Rotate reset
	Ctrl + Y	Focus out
	W	Target UP
	A	Target Left
	X	Target Down
	D	Target Right
	S	Go to Target
	J	PT camera Scan pipe joint

Table 9.4: Video commands and shortcuts

Keypad Key	Keyboard key		Description
	Ctrl +	A	Play
	Ctrl +	Q	Take snapshot
	Ctrl +	S	Pause
	Ctrl +	W	Text
	Ctrl +	X	Video stop
	Ctrl +	Z	Record

## 9.2 Care and maintenance

**⚠ WARNING!** Clean and sanitize the P350 flexitrax system with a suitable disinfectant at regular intervals to help prevent the risk of biological contaminations from foul water sources. Use appropriate gloves when cleaning the system.

Do not dismantle component parts, unless directed by this manual.

### 9.2.1 Terminals

**⚠ CAUTION!** Do not use damaged, dirty or corroded components, including all terminal connections, cables and O-rings.

Ensure that all terminals and connection points are clean and free of corrosion and debris before you attempt to use this equipment.

Check that any O-rings are clean, greased and not damaged. Use a silicon based grease such as "Super Lube".

Pearpoint recommends protecting all terminals with plastic protection caps when the system is not in use.

If possible, only assemble or disassemble system components in a dry and clean environment.

### 9.2.2 Cleaning the system

**⚠ WARNING!** Foul water systems can be a source of biological hazards; ensure you clean all equipment with a suitable disinfectant after use.

**CAUTION:** Do not use high-pressure hoses to clean this system.

### Command Module

- Clean the case with mild soapy water.
- Use lint-free cloth to clean the LCD screen.

### Crawler and Camera

- Clean with water and disinfectant.
- Clean the lens with a lint-free cloth.

### Cable and Drum

- Use a cloth moistened with disinfectant.

### 9.2.3 Storing the system

The P350 flexitrax is a precision system. Always store the system, including all components and accessories, in a clean and dry environment.

## 9.3 Upgrading software

Pearpoint may issue P350 system software updates to enhance performance and improve stability for any component of the system. To find out if Pearpoint has released a new software update, please visit [www.radiodetection.com](http://www.radiodetection.com) or contact your local Pearpoint representative. It is highly recommended that you periodically check for new software releases and update your system when software is made available.

Software downloads are free of charge.

The P350 system's integrated software is made up of several individual software files needed by each individual component to work and communicate correctly. Pearpoint releases all software in a zipped bundle. The zip file also includes a readme file that details the current version number for each software file.

**NOTE:** Your system may already have the latest software installed. Check your system's software versions against the version log in the readme file before you attempt to upgrade your system.

Press Fn + F4 to access the Software Versions info screen, see Figure 9.1. This screen displays all the software versions.

**NOTE:** The P350 Command Module, Drum and Crawler need to run compatible software versions, otherwise the system may not work correctly. If the software loaded on a component is incompatible with the rest of the system or missing, as a result of a failed upload, this is reported on the info pages. When a software mismatch or missing application on a component is reported, you need to complete a software upgrade on that component.

Figure 9.1: Software Versions info page

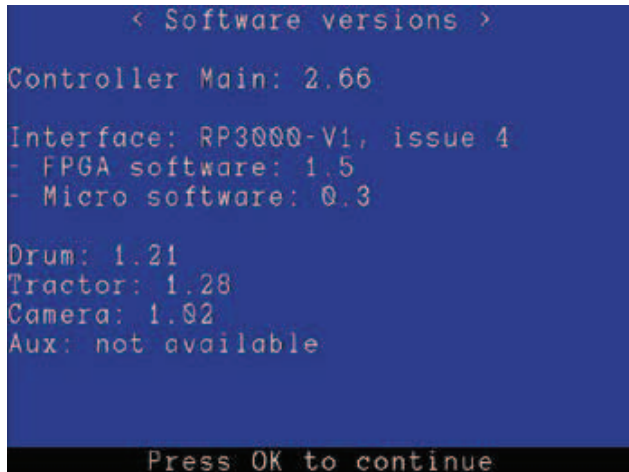

### Controller:

- controller.bin
- interface.bin

### Crawler

- tractor.bin

### Drum and PSU

- drum.bin

### Camera (PT and PTZ only)

- ptcamera.bin
- ptzcamera.bin

When new software is released, it is highly recommended that you upgrade every component to the latest software otherwise malfunctions may occur during operation.

To update your system, you must first download the software bundle containing the latest P350 software from [www.radiodetection.com](http://www.radiodetection.com).

Once you download the software bundle to your computer, extract them using WinZip or a similar archive package manager and copy the extracted files to the root directory of a Compact Flash card.

If you intend to use a Compact Flash card that contains survey files, be sure to back up the data on to your computer before continuing.

Insert the Compact Flash card into the command module and switch the system on.

**NOTE:** The system should be completely assembled if attempting to upload new crawler software. Please check the presence of the drum and crawler status indicators before attempting to update them.

**⚠ CAUTION!** Do not remove the Compact Flash card or switch off the system while the upgrade is in progress. Failure to comply may render the system inoperable.

**NOTE:** Upgrading components with the latest software may take several minutes. If the upgrade is successful, the command module may prompt you to reboot. Press OK to reboot the system.

**NOTE:** If you receive any error messages, check that you have copied all .BIN files to the root of the card and then try again.

### Camera (PT and PTZ) software

To check the camera's software version, see Figure 9.2:

SETUP->DEVCE ->CAM->INFO

To upgrade the camera's software:

SETUP->DEVCE->CAM->ULOAD

Figure 9.2: Camera info page

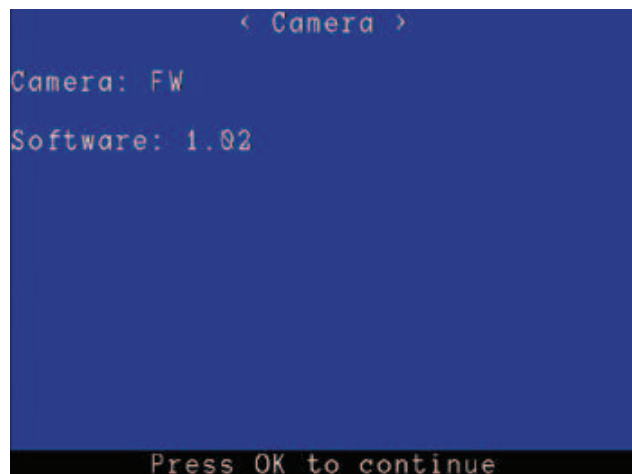

### Crawler software

To check crawler's software version, see Figure 9.3:

SETUP -> DEVCE -> TRACT -> INFO

To upgrade the crawler's software:

SETUP -> DEVCE -> TRACT -> ULOAD



Figure 9.3: Crawler info page

```
< Tractor >
Tractor: P356
Tractor software: 1.28
Aux: none
Wheel diameter: 170mm
Active: 755 hours since 26/2/2009
Press OK to continue
```

### Powered drum and manual PSU

To check the powered drum and manual PSU's software version, see Figure 9.4:

SETUP -> DEVCE -> REEL -> DRUM -> INFO

To upgrade the drum and manual PSU's software:

SETUP -> DEVCE -> REEL -> DRUM -> ULOAD

Figure 9.4: Drum info page

```
< Drum >
Reel: Powered Drum 250m
Software: 1.22
Auto-stop set at 0.00m
Press OK to continue
```

### Command module

To check the command module's software version, see Figure 9.5:

SETUP -> DEVCE -> CONTR -> UPDTE -> INFO

To upgrade the command module's main software:

SETUP -> DEVCE -> CONTR -> UPDTE -> MAIN

To upgrade the command module's interface software:

SETUP -> DEVCE -> CONTR -> UPDTE -> IFACE

Figure 9.5: Command module info page

```
< P350 flexitrax >
Controller Main: 2.67 (Mar 16 2010)
Unit ID: 8MU
FPGA F/W: 1.3
DSP S/W: 2.32
H264 F/W: 0.2.3, p.code 55
Bootloader: 2.0
Interface: RP3000-V1, issue 4
- FPGA software: 1.5
- Micro software: 0.3
BlueTooth F/W: 9.24.0 PA
Press OK to continue
```

If a software upgrade has been successful the system will display a message saying "Upload OK". Press OK to continue.

If a software upgrade has failed a message will be displayed indicating the error. If this happens perform the upgrade again.

### 9.4 Crawler cable re-termination

You must re-terminate the cable if you suspect that video, power or communication signals are in anyway degraded. This may be indicated by poor video quality, intermittent power shortages or an unresponsive crawler.

The **P350 flexitrax crawler cable re-termination guide** is available to download from the download section of the Radiodetection website: [www.radiodetection.com](http://www.radiodetection.com).

This guide provides a detailed, step by step, guide on how to re-terminate the crawler cable.

The cable re-termination procedure should only be performed by skilled and adequately trained technicians.

Figure 9.6: Drum cassette replacement (exploded)

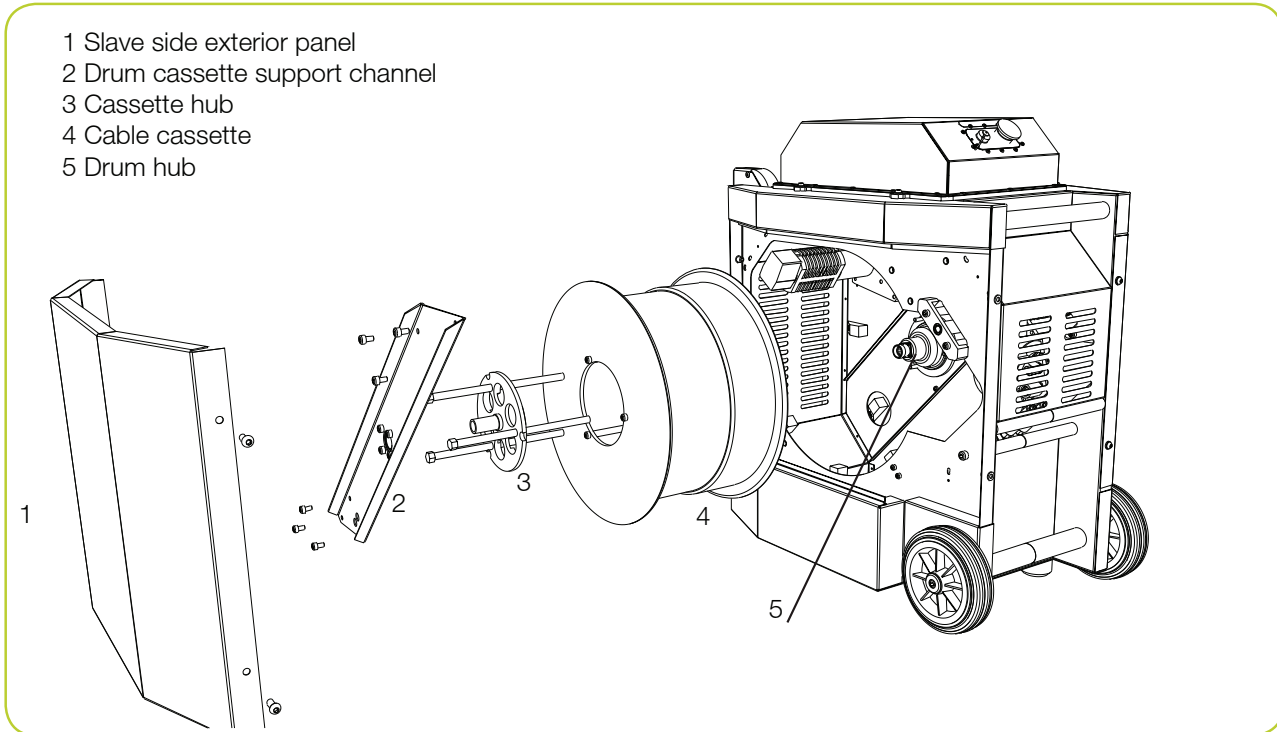

## 9.5 Cable drum replacement

In the powered drum, the cable is housed in a cassette. This component is user-replaceable. The following procedure outlines the removal and replacement of the cable cassette.

**⚠ WARNING! Switch the system off and disconnect the power lead and all other cables before you continue.**

### 9.5.1 Disassembly

1. Remove the slave-side panel, see Figure 9.6.
2. Remove the drum cassette support channel, see Figure 9.7.
3. The drum cassette is held in place by the cassette hub. Do not remove this hub yet; proceed to the next step.
4. Remove the cable from the cable layering mechanism. To do so:
  - a. Lift the spring loaded pinch roller to the upright position, see Figure 9.10.
  - b. Unfasten the cable retaining rollers. The rollers are held in place by thumb screws on the reverse side of the cable layering mechanism.

5. Finally remove the top horizontal exterior cable guide (Figure 9.7).
6. Remove the cassette hub.
7. Disconnect the internal cassette cable connector from the drum hub.
8. You can now remove the cassette from the drum hub

Figure 9.7: Powered drum with slave side panel and drum support channel removed

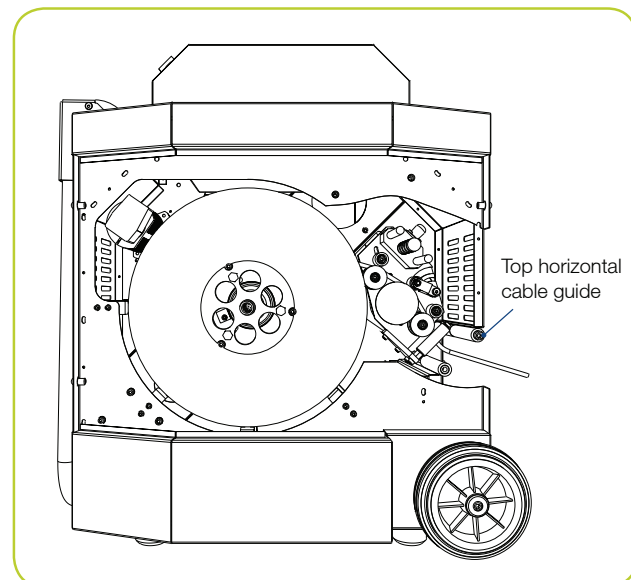

## 9.5.2 Assembly

1. Replace the drum cassette as required.
2. Re-connect internal cassette connector to the drum hub (Figure 9.6).
3. Secure the cassette hub.
4. Re-fit the drum cassette support channel.
5. Thread terminated cable through layering mechanism ensuring both cable retaining rollers (Figure 9.9) are returned to their 'locked' position and that the spring loaded pinch roller is in its down position.
6. Re-fit top horizontal cable guide (Figure 9.7).

**NOTE:** Special care is required when threading the cable from the cable layering mechanism. You must correctly align the cable mechanism to match the cable's position on the drum otherwise the cable may become entangled. Proceed as described below.

The cable layering mechanism (Level Wind) features a leadscrew that allows the layering mechanism to move in two directions. When you retrieve the cable, this must be in-line with the follower (see Figure 9.9).

To synchronize the follower to the drive train and the cable, you may have to adjust the follower's position manually. To do so:

1. Slacken the 2-off internal M6x10 screws and move the chain tensioning block downwards (Figure 9.8).
2. Remove the level wind chain drive.
3. Adjust position of follower by turning the sprocket located on the end of the leadscrew to ensure the follower is in-line with the cable exiting the drum cassette (Figure 9.9).
4. Re-fit the level wind chain drive. Manually pull the cable from the drum and ensure that the follower moves in the correct direction when the cable is spooling off the drum cassette. If this is not the case, remove the level wind chain again and manually rotate the level wind sprocket (maintaining the same direction) until the follower has gone right to the end of its travel and returned to the original position.
5. Re-attach the level wind chain drive, move the chain tensioning block upwards ensuring both chains are in tension prior to fully tightening the 2-off M6x10 screws.
6. Replace both the drive & slave side panels.

Figure 9.8: Adjusting the drive train

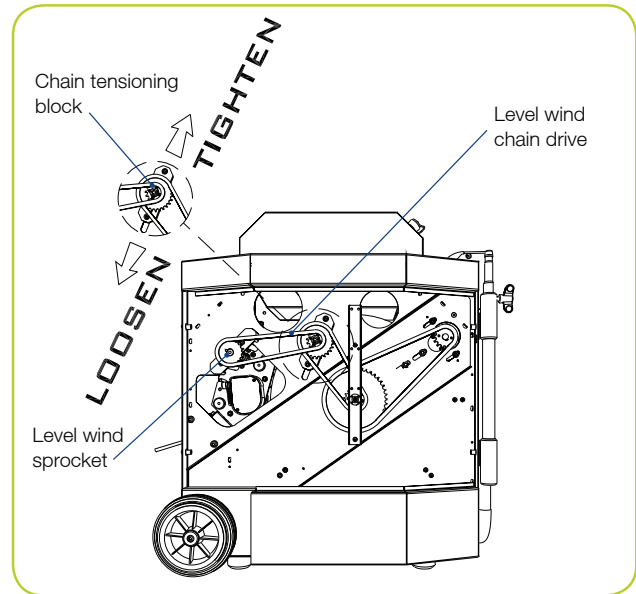
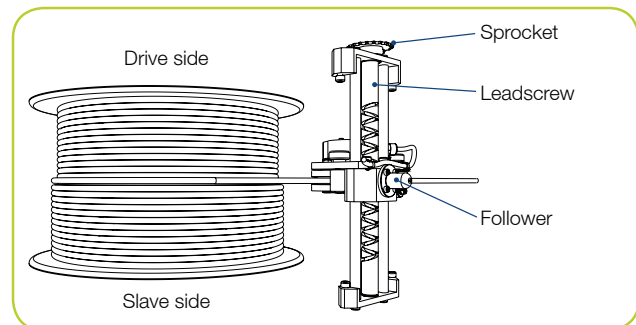

Figure 9.9: Cable layering sprocket and follower



## 9.5.3 Replacing cable

You can replace the cable in the cassette if required.

To do so (see Figure 9.11):

1. Disconnect the power and crawler from the system.
2. Pull the cable slowly out by hand.
3. Disassemble the system and remove the cable cassette following the guide in Section 9.5.1.
4. Remove the cassette's strain relief clamp and remove the remaining part of the cable end.
5. Insert new cable end into the drum; allow 500mm slack when you re-fit the cable to the strain relief clamp on the inside of the cassette.
6. Re-assemble the system using the procedure described in Section 9.5.2 ensuring the level wind follower (Figure 9.9) is in line with the entrance hole into the drum cassette.
7. Reconnect the power cable and switch the system on.
8. Use manual drive mode to wind the cable back in to the drum.

Figure 9.10: Cable layering mechanism

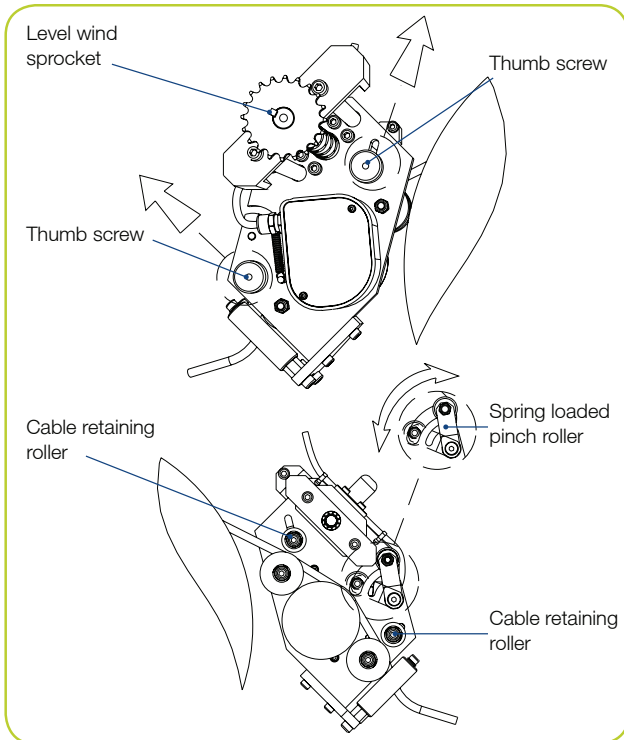
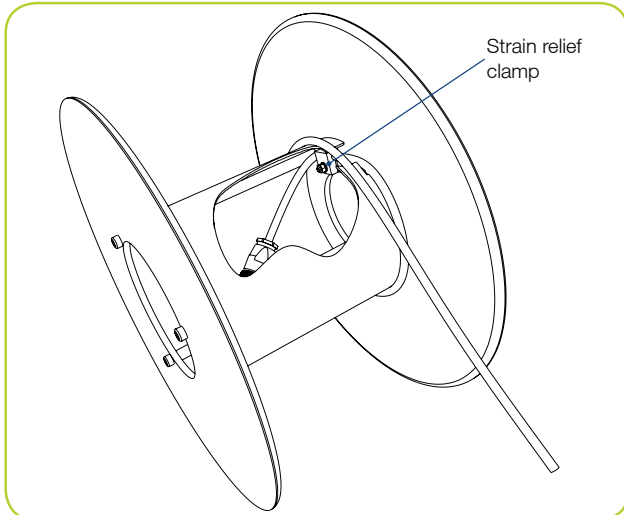

Figure 9.11: Cable drum cassette



## 9.6 AVC Video licence

Use of the images recorded with this equipment is permitted as supporting evidence of a professional survey or report. This product is licensed under the AVC Patent Portfolio License for the personal and non-commercial use of a consumer to (i) Encode video in compliance with the AVC standard ('AVC Video') and/or (ii) Decode AVC video that was encoded by a consumer engaged in a personal and non-commercial activity and/or was obtained from a video provider licensed to provide AVC video. No license is granted or shall be implied for any other use. Additional Information may be obtained from MPEG LA, L.L.C. See <http://www.mpegla.com>.

## 9.7 Defect codes text file

The defect codes file is a plain text file containing a list of all defect codes and their description. This file must be named "defect\_codes.txt" and be saved in the root of your Compact Flash card.

You can easily create or edit this file using any plain text editor like Notepad for Windows or TextEdit for Mac OS X. Alternatively, you can create your file in most word processors and export the document to plain text using the Save As or Export function depending on your word processing package.

**NOTE:** By default TextEdit for Mac OS X produces rich text files, which cannot be used as the defect code file. To change to plain text format go to Format -> Make Plain Text.

The structure of this file is simple:

Each row is a new entry. The defect code starts from the first character and the description is placed after one or more tab characters. Table 9.6 describes the correct structure of the defect\_codes.txt file. Note that the >> symbol is a representation of the tab character for illustration purposes only. A tab character is inserted when you press the tab key on your computer's keyboard.

**Table 9.6: Defect\_codes.txt structure**

Code	Tab char.	Description
C L	>>	Crack, longitudinal at ... o'clock
CC	>>	Crack, circumferential from ... to ... o'clock
CM	>>	Cracks, multiple from ... to ... o'clock
F L	>>	Fracture, longitudinal at ... o'clock

**NOTE:** The heading text is for descriptive purposes only. Do not include this line in the text document as P350 system will treat it like a defect code.

### 9.7.1 Text encoding

The “defects\_codes.txt” file must be encoded in the ANSI or ASCII standard to display on screen correctly. Notepad for Windows automatically encode files using the ANSI format.

Some text editors, may automatically encode files using the unicode format. Unicode text is compatible with the P350 system’s generated reports, however some unicode characters may not be displayed correctly on the P350’s screen. Should this problem occur, you can correct it by opening the defect\_code.txt file in your plain text editor and changing the encoding to ANSI or ASCII format.

**NOTE:** On Mac OS X and several Linux systems, ANSI encoding is referred to as Western (Windows Latin 1).

## 9.8 Specifications

### 9.8.1 Environmental specifications

Environmental\* IP53 (Surface Equipment): IP68 to 100m/11bar (Downhole Equipment).

Temperature (Storage): -20 to 80°C (-4 to 176°F).

Temperature (Operating): -10 to 50°C (14 to 122°F).

\*Unless otherwise stated.

### 9.8.2 Command module

Command module	P350-CMOD
Screen	200mm / 8" Industrial TFT, SVGA
Storage	High Speed Compact Flash
Recording Time (hrs)*	1:45 (HQ) - 3:45 (MQ) - 9:00 (LQ)
Connectivity	USB 2.0, Video In/Out, Audio In/Out, Ethernet, <i>Bluetooth</i> <sup>®</sup>
Dimensions	300 x 360 x 200mm / 14" x 14" x 8"
Weight	5.5kg /12lbs

\*Based on a 2GB Compact Flash card

### 9.8.3 Cable Drums

Drums	P350-DRUM-M	P350-DRUM-P
Dimensions (L x W x H) Drum	445 x 270 x 570mm 17.5" x 10.6" x 22.4"	633 x 412 x 740mm 24.9" x 16.2" x 29.1"
Dimension (L x W x H) external Power Supply	418 x 195 x 420mm 16.5" x 7.7" x 16.5"	Integral
Weight external Power Supply	15.8kg	Integral
Weight Drum	18kg to 29kg / 39.7lbs to 64lbs depending on cable length	59kg to 70kg / 130lbs to 154lbs depending on cable length
Construction	Powder-coated tubular steel frame with steel and aluminum power pack enclosure. Stainless steel and aluminum manual cable management mechanism	Powder-coated steel chassis with steel and aluminum enclosure. Interchangeable alloy cable drum. Stainless steel and aluminum automatic cable management mechanism
Power	110-240V 50-60Hz 1.2kVA. Generator (if used) to have inverter-type output	

### 9.8.4 Crawlers

Crawlers	P354	P356
Pipe diameter	100mm (4") to 300mm (12")	150mm (6") to 600mm (24")
Dimensions (L x W x H)	250mm (9.8") x 82mm (3.2") x 69mm (2.7")	345mm (13.6") x 128 (5") x 84 (3.3")
Weight	5.4kg (12lbs)	14kg (31lbs) approx.
Motors	1 x 50W	2 x 50W
Construction	Brass and Stainless Steel	Brass and Stainless Steel
Sonde frequency	512/640/8192/32768 Hz	512/640/8192/32768 Hz
Inclinometer accuracy	± 0.2°	± 0.2°

\*Minimum specified diameter must be maintained along the whole length of the survey

### 9.8.5 Cameras

Cameras	P350-CAM-FW	P350-CAM-PT	P350-CAM-PTZ
Dimensions (L x Diameter)	62 x 68mm / 2.4" x 2.7"	134 x 68mm / 5.3" x 2.7"	158 x 90mm / 6.2" x 3.5"
Weight	600g / 1.3lbs	1.8kg / 4.0lbs	2.9kg / 6.4lbs
Construction	Stainless Steel	Stainless Steel	Stainless Steel
Focal Range	10mm to ∞	10mm to ∞	10mm (WIDE) to ∞
Horizontal Resolution	≥ 460TVL	≥ 460TVL	≥460 TVL
Sensitivity	< 1.0 Lux	< 1.0 Lux	1.0 Lux @ f1.8
LED luminance	≥ 120lm	≥ 210lm	≥ 420lm

## 9.8.6 Auxiliary lighthouse

Auxiliary lighthouse	P350-LH-8
Dimension (L x Diameter)	63 x 136mm / 2.5" x 5.4"
Weight	1.8kg / 4.0lbs
Construction	Stainless Steel and Aluminum
LED Luminance	≥ 850lm

## 9.8.7 Elevators

Elevators	P350-ELV-F (Fixed Elevator)	P350-ELV-A (Adjustable Elevator)	P350-ELV-LAM (Large Manual Elevator)
Weight	0.4kg / 0.9lbs	0.7kg / 1.5lbs	4.5kg / 9.9lbs
Construction	Stainless Steel and Aluminum	Stainless Steel	Stainless Steel and Aluminum
Pipe Range (P354)	up to 300mm / 12"	up to 380mm / 15"	Not available
Pipe Range (P356)	up to 380mm / 15"	up to 458mm / 18"	300mm to 600mm 12" to 24"

## 9.8.8 Pendant Controller

Pendant Controller	P350-PENDANT
Dimension (L x Diameter)	250 x 80 x 40mm / 9.8" x 3.1" x 1.6"
Weight	0.7kg / 1.5lbs
Construction	Linear Medium Density Polyethylene (LMDPE) and mild steel
IP Rating	IP64

## 9.8.9 Approvals

### Safety:

- EN 61010-1:2001
- IEC 61010-1:2001
- UL 61010-1: 2004

### EMC:

- EN 61326-2-1: 2006 (Class A Emissions / Basic Immunity)

### Environmental:

- BS EN 60529 (IP53)
- BS EN 60068-2-64 BS (Vibration)
- EN 60068-2-27 (Shock)

## America

### Radiodetection

154 Portland Road  
Bridgton, ME 04009, USA  
Tel: +1 (207) 647 9495  
Toll Free: +1 (877) 247 3797  
Fax: +1 (207) 647 9496  
Email: rd.sales.us@spx.com  
Web: www.radiodetection.com

### Pearpoint

39-740 Garand Lane, Unit B  
Palm Desert, CA 92211, USA  
Tel: +1 800 688 8094  
Tel: +1 760 343 7350  
Fax: +1 760 343 7351  
Email: pearpoint.sales.us@spx.com  
Web: www.radiodetection.com

### Radiodetection (Canada)

344 Edgeley Boulevard, Unit 34  
Concord, Ontario L4K 4B7, Canada  
Tel: +1 (905) 660 9995  
Toll Free: +1 (800) 665 7953  
Fax: +1 (905) 660 9579  
Email: rd.sales.ca@spx.com  
Web: www.radiodetection.com

## Europe

### Radiodetection Ltd (UK)

Western Drive  
Bristol BS14 0AF, UK  
Tel: +44 (0) 117 976 7776  
Fax: +44 (0) 117 976 7775  
Email: rd.sales.uk@spx.com  
Web: www.radiodetection.com

### Radiodetection (France)

13 Grande Rue, 76220  
Neuf Marché, France  
Tel: +33 (0) 2 32 89 93 60  
Fax: +33 (0) 2 35 90 95 58  
Email: rd.sales.fr@spx.com  
Web: <http://fr.radiodetection.com>

### Radiodetection (Benelux)

Industriestraat 11  
7041 GD 's-Heerenberg, Netherlands  
Tel: +31 (0) 314 66 47 00  
Fax: +31 (0) 314 66 41 30  
Email: rd.sales.nl@spx.com  
Web: <http://nl.radiodetection.com>

### Radiodetection (Germany)

Groendahlscher Weg 118  
46446 Emmerich am Rhein, Germany  
Tel: +49 (0) 28 51 92 37 20  
Fax: +49 (0) 28 51 92 37 520  
Email: rd.sales.de@spx.com  
Web: <http://de.radiodetection.com>

## Asia-Pacific

### Radiodetection (Asia-Pacific)

Room 708, CC Wu Building  
302-308 Hennessy Road, Wan Chai  
Hong Kong SAR, China  
Tel: +852 2110 8160  
Fax: +852 2110 9681  
Email: rd.sales.cn@spx.com  
Web: www.radiodetection.com

### Radiodetection (China)

Hongfu Mansion, Room 61622  
Zheng Ge Zhuang, Bei Qi Jia Town  
Chang Ping District  
Beijing 102209, China  
Tel: +86 (0) 10 8975 5540  
Fax: +86 (0) 10 8975 5640  
Email: rd.service.cn@spx.com  
Web: <http://cn.radiodetection.com>

### Radiodetection (Australia)

Unit H1, 101 Rookwood Road,  
Yagoona NSW 2199, Australia  
Tel: +61 (0) 2 9707 3222  
Fax: +61 (0) 2 9707 3788  
Email: rd.sales.au@spx.com  
Web: www.radiodetection.com

Copyright 2011 Pearpoint Ltd./ Radiodetection Ltd – SPX Corporation. All rights reserved.  
Radiodetection is a subsidiary of SPX Corporation. SPX, Radiodetection and flexitrac  
are trademarks of Radiodetection Ltd. and SPX Corporation. Due to a policy of  
continued development, we reserve the right to alter or amend any published specification  
without notice. This document may not be copied, reproduced, transmitted, modified or  
used, in whole or in part, without the prior written consent of Radiodetection Ltd.

To see the full range of products and services provided by Radiodetection visit:

[www.radiodetection.com](http://www.radiodetection.com)

